



RELIANCE™ - TC LT

installation & glazing manual

NOTE

THE INSTALLATION DETAILS FOUND IN THIS PACKAGE ARE GENERIC AND ARE FOR REPRESENTATION ONLY WITH THE INTENT OF GIVING THE INSTALLATION TEAM A VISUAL REPRESENTATION AS TO HOW THE ASSEMBLIES TYPICALLY INSTALL. THE SHOP SUBMISSION DRAWINGS AND DETAILS ARE THE GOVERNING DOCUMENTS AND AS SUCH THIS PACKAGE IS TO BE USED ONLY AS A RESOURCE.

FOLLOW SEALANT MANUFACTURERS' RECOMMENDATIONS FOR USE AND APPLICATION OF ALL STRUCTURAL SILICONE SEALANT AND WEATHER SEAL SILICONE SEALANT.

CUSTOMER / PROJECT QUALITY ASSURANCE PROCEDURES ARE SEPARATE DOCUMENTS AND ARE TO BE FOLLOWED IN CONJUNCTION WITH THIS MANUAL.

RELIANCE™ - TC LT Curtain Wall Installation and Glazing Manual

Contents

QUICK REFERENCE GUIDE:	3
IMPORTANT NOTICE:	4
GENERAL NOTES	4
SPECIAL NOTE	4
ARCHITECTURAL PRODUCT	4
BUILDING CODES	4
STRUCTURAL SEALANTS	4
PERIMETER SEALANTS.....	5
MATERIAL AND WORK ACCEPTANCE	5
MATERIAL HANDLING, PROTECTION, AND STORAGE.....	6
EXPANSION JOINTS	6
GLASS	6
CLEANING	6
GENERAL CONSTRUCTION NOTES	6
SUGGESTIONS FOR IMPROVING SYSTEM THERMAL PERFORMANCE.....	7
GLASS INFORMATION	8
1.0 Glass Sizing	8
FRAME FABRICATION.....	9
2.0 Determine Installation Type	9
3.0 Establish Frame Size	10
4.0 Cut Members to Size	11
5.0 Vertical Fabrication	14
6.0 Vertical Fabrication at Expansion Horizontal.....	19
7.0 Horizontal Fabrication.....	21
8.0 Horizontal Fabrication at Expansion Horizontal	25
9.0 Pressure Plate and Cover Fabrication	30
10.0 Reinforcement.....	31
FRAME INSTALLATION AND ASSEMBLY.....	32
11.0 Vertical Member Assembly	32
Shear Block Attachment	32
"F" Anchor Auxiliary Fastener Installation.....	34
Pocket Filler Attachment.....	34
Mullion Cap Installation	35
Splice Sleeve Installation.....	36
Optional Transition Glazing Adaptor Tongue Installation (SSG to Captured).....	37
12.0 Single Span Vertical Installation.....	37
13.0 Twin Span Vertical Installation.....	39
14.0 Multi-Span Vertical Installation	40
15.0 Horizontal Member Assembly.....	41
Pocket Filler Attachment.....	41
Expansion Horizontal Gasket Retainer Attachment.....	42
16.0 Horizontal Installation and Sealing	43
17.0 Horizontal Expansion / Vertical Splice Installation & Sealing	47
Standard Vertical Splice	47
Horizontal Expansion Mullion	47
18.0 Perimeter Sealing	52
GLAZING	53
19.0 Optional Glazing Adapter Installation	53
20.0 Preparation of Frame Opening for Glass	55
21.0 Interior Gasket and Setting Blocks	56

1-866-OLDCASTLE (653-2278)

OBE.com

Version: 2023-1013

Copyright © 2023 Oldcastle BuildingEnvelope®
All rights reserved.

™ © Trademarks of Oldcastle BuildingEnvelope and its affiliated companies or respective owners.

RELIANCE™ - TC LT Curtain Wall Installation and Glazing Manual

22.0	Setting Glass	58
23.0	SSG Application and Sealing.....	60
24.0	Pressure Plate and Face Cap Installation	61
25.0	Face Cap Fastening (Safety Fasteners)	66
REGLAZING.....		67
26.0	Reglazing Procedure.....	67
CORNERS.....		68
27.0	Captured OS 90° Corner Assembly	68
28.0	Captured OS 135° Corner Assembly	69
29.0	SSG OS 90° Corner Assembly.....	70
30.0	SSG OS 135° Corner Assembly.....	71
31.0	SSG IS 90° Corner Assembly.....	72
DOORS		73
32.0	Door framing	73
PARTS LIST		74
Installation Checklist.....		84

QUICK REFERENCE GUIDE:

- Aluminum Pressure Plate Fasteners
 - Locate @ 9" O.C. and 1-1/2" from each end
 - Torque to 60 in-lbs
- Polyamide Pressure Plate Fasteners
 - Locate @ 6" O.C. and 1-1/2" from each end
 - Torque to 50 in-lbs
- Glass Sizing
 - Glass Width =
D.L.O. plus (+) 1/2" per Captured Mullion plus (+) 3/4" per SSG Mullion
 - Glass Height =
D.L.O. plus (+) 1"

RELIANCE™ - TC LT Curtain Wall Installation and Glazing Manual

IMPORTANT NOTICE:

Completely read these instructions prior to beginning work. These recommendations are for general erection/installation procedures only. For actual job conditions, see shop drawings if applicable. For perimeter anchor types and spacing, refer to the approved shop drawings or consult structural engineer/project design professional.

GENERAL NOTES

The RELIANCE™ - TC LT curtain wall system is intended for installation by glazing professionals with appropriate experience. Subcontractors without experience should employ a qualified person to provide field instruction and project management.

Check all shop drawings and installation instructions to become familiar with the project before work begins. The shop drawings take precedence and include specific details for the project. The installation instructions are of a general nature and only cover the most common conditions.

SPECIAL NOTE

The air and water performance of the RELIANCE™ - TC LT curtain wall system is directly related to the accuracy of the installation and glazing processes. All pressure plates must also be installed properly. To ensure performance for this system, particular attention should be given the following procedures.

- A. Surfaces to be sealed should be cleaned with isopropyl alcohol or solvent and dried as recommended by sealant manufacturer to remove all dirt and cutting oils. Sealant at shear blocks should be a minimum 3/16" Ø nominal placed completely around the top, face and bottom of the shear block without gaps in the sealant. Exposed surfaces should be cleaned after installing the horizontal. Inspect joint for complete sealant contact, especially where the horizontal meets the face of the vertical member. Repair joint as required.
- B. The interior glazing gasket should be installed so as to avoid stretching, buckles or tears. Corners must be cut square, sealed and butted together. To avoid damage to gasket and corner joints during glazing, glass should be level and straight during installation.
- C. Vertical movement of mullion at intermediate floors requires special expansion joints and glazing materials. See *Figure 41* and *Figure 40* for details which permit 1/4" & 3/4" movement. For designs and applications that may require greater movement or special considerations please contact your local Oldcastle BuildingEnvelope® facility.

ARCHITECTURAL PRODUCT

It is the responsibility of Oldcastle BuildingEnvelope® to supply a system to meet the architect's specification.

BUILDING CODES

Oldcastle BuildingEnvelope® does not control the application nor selection of its product configurations, sealant, or glazing materials, and assumes no responsibility thereof. It is the responsibility of the owner, architect, and installer to make these selections in strict compliance with applicable laws and building codes.

STRUCTURAL SEALANTS

The fabrication and installation of a structural silicone-glazed (SSG) system requires more technical knowledge and experience than is required for a conventional pressure-glazed system. The glazing contractor should take all steps as outlined and required by the structural silicone sealant manufacturer, glass fabricator, framing manufacturer, and the project professional engineer of record as well as follow local building code requirements and industry best practices to ensure the proper installation and safe performance of the SSG system.

The glazing contractor for each project needs to ensure compliance with each step, including, but not limited to, design reviews, formal adhesion testing, formal compatibility testing, project specification compliance,

1-866-OLDCASTLE (653-2278)

OBE.com

Version: 2023-1013

Copyright © 2023 Oldcastle BuildingEnvelope®
All rights reserved.

™ ® Trademarks of Oldcastle BuildingEnvelope and its affiliated companies or respective owners.

RELIANCE™ - TC LT Curtain Wall Installation and Glazing Manual

validating procedures, field testing, and quality control validation of installed product and surrounding conditions.

Testing of component materials for use in a SSG system is mandatory to fulfill project specifications and warranty requirements and must be submitted by the glazing contractor to the structural silicone manufacturer. All materials that comprise the structural silicone joint, such as the framing system (with the job-specific finish) and job-specific glass must be tested by the structural silicone manufacturer for compatibility and adhesion. All other accessory materials in contact with the structural silicone, such as setting blocks, spacers, gaskets, sweeps, air seals and expansion joints, must also be submitted to the silicone sealant manufacturer for compatibility testing.

To ensure that nothing has changed in formulation or chemistry since the initial tests, subsequent testing during periodic time frames of the project is to be conducted to confirm continued acceptance of the material for use on the project.

To ensure the structural performance and integrity of the insulating glass unit (IGU), the glazing contractor must submit the project shop drawings to the glass fabricator to obtain approval for use of their product(s) in any 2, 3 or 4-sided SSG applications.

Quality control procedures for field glazing are to be increased beyond those required for shop glazing. Job conditions will normally have dust, dirt, and other construction debris on the surfaces where structural silicone is to be applied. Great care should be exercised in cleaning and preparing these surfaces for silicone application. The recommendations of the silicone sealant manufacturer are to be strictly enforced and followed. The fabrication and installation of the SSG system and its components, whether shop or field glazed, should be governed by a quality control program, and all steps, procedures, and test reports should be documented throughout the project.

Store sealants at recommended temperature and check container for remainder of shelf life before using. Use primers where directed by sealant manufacturer.

For Structural Silicone Glazing applications, the stress on the silicone shall not exceed 20 PSI. Consult sealant manufacturer for specific applications to ensure proper loading on silicone joint. Alternate spacer gaskets may be available to accommodate larger sealant contact widths. Consult your nearest Oldcastle BuildingEnvelope® facility for assistance.

Prior to installation of any SSG system, refer to industry documents (e.g., AAMA Curtain Wall Design Guide Manual, ASTM C1401-14, and AAMA SSGDG-17) for detailed instructions and recommendations.

THE GLAZING CONTRACTOR ASSUMES FULL RESPONSIBILITY FOR ENSURING COMPLIANCE WITH THE ABOVE, AND ASSUMES FULL LIABILITY FOR ANY ISSUES ARISING FROM NONCOMPLIANCE.

PERIMETER SEALANTS

Due to varying job conditions, all perimeter sealants used should be approved by the sealant manufacturer to ensure the sealant will function for the conditions shown in these instructions and shop drawings. Sealants must be compatible with all surfaces where adhesion is required, including other sealant surfaces. Use primers where directed by sealant manufacturer. Be sure to store sealants at recommended temperature and check container for remainder of shelf life before using.

MATERIAL AND WORK ACCEPTANCE

OLDCASTLE BUILDINGENVELOPE® MATERIALS

Check all material upon arrival for quality and to assure against shipping damage. Any visible damage must be noted on the freight bill at the time of receipt. If a claim is required, then the receiving party must process a claim with the freight company.

1-866-OLDCASTLE (653-2278)

OBE.com

Version: 2023-1013

Copyright © 2023 Oldcastle BuildingEnvelope®
All rights reserved.

™ ® Trademarks of Oldcastle BuildingEnvelope and its affiliated companies or respective owners.

RELIANCE™ - TC LT Curtain Wall Installation and Glazing Manual

OTHER TRADES WORK

Completely check construction that will receive your materials against contract documents. Notify general contractor by letter of any discrepancies before proceeding with work. Failure to do so constitutes acceptance of work by other trades.

MATERIAL HANDLING, PROTECTION, AND STORAGE

Handle the material carefully. Do not drop from the truck. Stack with adequate separation so that the material will not rub together. Store material off the ground. Protect against the elements and other construction hazards by using a well-ventilated covering away from other trades. Remove material from package if it is wet or located in a damp area.

SHOP

- Cardboard wrapped or paper interleaved material must be kept dry. Immediately remove aluminum from cardboard or paper interleaved materials should it get wet to prevent staining or etching the aluminum finish.
- Check arriving materials for quantity and keep record of where various materials are stored.

JOB SITE

- Material at job site must be stored in a safe place well removed from possible damage by other trades.
- Cardboard wrapped or paper interleaved materials must be kept dry. Immediately remove aluminum from cardboard or paper interleaved materials should it get wet to prevent staining or etching the aluminum finish.
- Keep record of where various materials are stored.
- Protect materials after erection. Cement, plaster, and other alkaline solutions are very harmful to the finish.

EXPANSION JOINTS

Expansion joints and perimeter seals shown in these instructions and in the shop drawings are shown at standard size. Actual dimensions may vary due to perimeter conditions and/or differences in metal temperature between the time of fabrication and time of installation. For example, a 12-foot unrestrained length of aluminum extrusion can expand or contract 3/32 of an inch over a 50-degree Fahrenheit change. Any movement potential should be accounted for at time of the installation.

GLASS

Glazing gaskets are designed for a compression fit against glass and can accommodate (+/- 1/32"). Be sure to check overall glass size and thickness.

Consult glass manufacturer for correct setting block location and length for glass sizes in excess of 40 sq./ft.

CLEANING

Final cleaning of exposed aluminum surfaces should be done in accordance with AAMA 609.1 for anodized aluminum and AAMA 610.1 for painted aluminum. Cement, plaster, terrazzo, alkaline and acid-based materials used to clean masonry are very harmful to finishes and should be removed immediately or permanent staining will occur. A spot test is recommended before any cleaning agent is used. Aluminum shall be cleaned with plain water containing a mild detergent. No abrasive agent shall be used.

GENERAL CONSTRUCTION NOTES

- A. Study these instructions, shop drawings, erection drawings, and architectural drawings before starting any work. Follow installation and glazing instructions.

RELIANCE™ - TC LT Curtain Wall Installation and Glazing Manual

- B. Completely check construction which will receive your materials against contract documents. Notify the general contractor by letter of any discrepancies before proceeding with your work since this constitutes acceptance of work by other trades.
- C. Coordinate protection of installed materials with general contractors and other trades.
- D. Do not install wall if there is a walkway with a downslope towards an entrance or a storefront.
- E. All materials are to be installed plumb and level.
- F. All work should start from an established benchmark and column centerlines established by the architect and the general contractor.
- G. Protect all aluminum to be placed directly in contact with uncured masonry or incompatible materials with a heavy coat of zinc chromate or bituminous paint.
- H. After sealant is set and a representative amount of the wall has been glazed (500 square feet or more), run a water hose test to check installation. On large jobs, hose test should be repeated during glazing operation. Test should be conducted in accordance with AAMA 501.2 specifications. This test should not be performed at entrances installed in the system.

SUGGESTIONS FOR IMPROVING SYSTEM THERMAL PERFORMANCE

To maintain or improve your wall installation the following items should be considered.

- A. Blinds or drapes prevent warm air from adequately flowing over the window surface.
- B. Warm air ventilators too far from the window will not adequately wash the window with air to prevent condensation.
- C. In extreme conditions the fan of the heating system should not cycle on and off, but should run continuously.
- D. Some heating systems have a water injection feature that can raise humidity levels. the higher the humidity level the more likely condensation or frost will form. Raising the temperature and reducing humidity will usually solve the problem.
- E. On rare occasions an extremely cold storm may cause frost to appear on the glass framing. A space heater and electric fan blowing along the plane of the window wall can reduce or eliminate this temporary condition.

RELIANCE™ - TC LT Curtain Wall Installation and Glazing Manual

GLASS INFORMATION

1.0 Glass Sizing

Note: Glass tolerances are not addressed in the formula below. Consult glass manufacturer for glass tolerances prior to ordering.

1.1 Basic Glass Size Calculation:

Glass Width = D.L.O. plus (+) 1/2" per Captured Mullion plus (+) 3/4" per SSG Mullion

Glass Height = D.L.O. plus (+) 1"

1.2 Corner Glass Size Calculation: See Figure 1

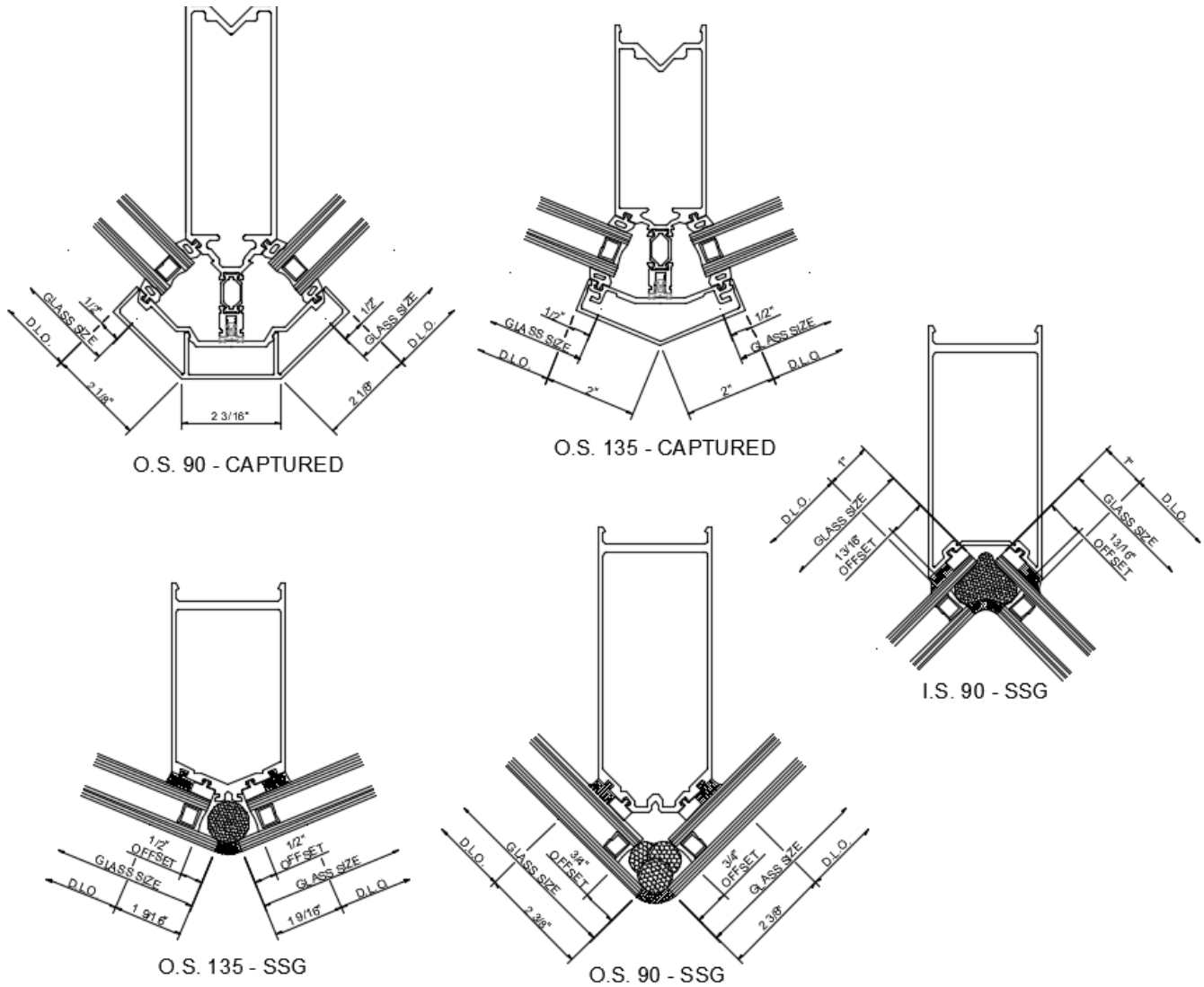

Figure 1: Glass Sizing

RELIANCE™ - TC LT Curtain Wall Installation and Glazing Manual

FRAME FABRICATION

2.0 Determine Installation Type

The following diagrams represent common types of installation for this product. Refer to approved shop drawings for specifics regarding splicing and anchoring of frame.

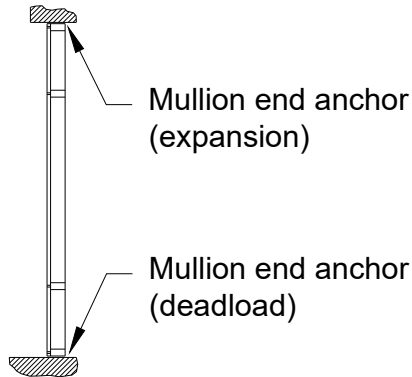

Figure 2: Single Span

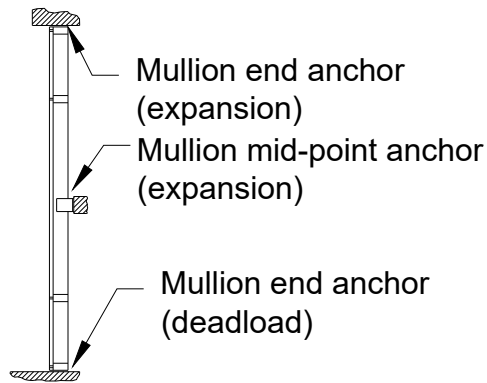

Figure 3: Twin Span

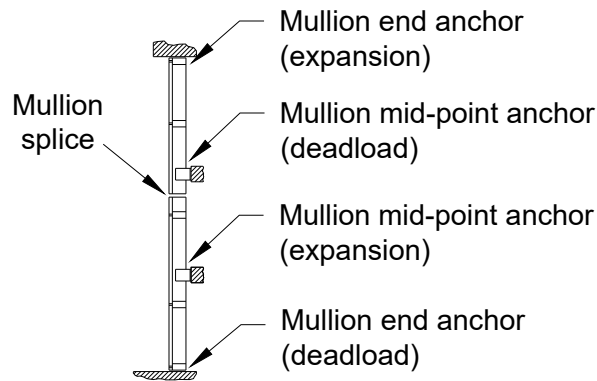

Figure 4: Multi-Span

RELIANCE™ - TC LT Curtain Wall Installation and Glazing Manual

3.0 Establish Frame Size

NOTE: The opening must be square and plumb before installation.

When measuring the rough opening, take multiple measurements and use the smallest dimension. This assures a proper fit of the storefront system.

Measure width of Rough Opening.

- A. Measure opening at bottom.
- B. Measure opening at center.
- C. Measure opening at top.

The Frame Width will be the smallest dimension minus (-) 1/2" allowing for a minimum of 1/4" caulk joint at each jamb.

Repeat process to determine Frame Height.

- A. Measure opening from top to bottom of left side.
- B. Measure opening from top to bottom of middle.
- C. Measure opening from top to bottom of right side.

The Frame Height will be the smallest dimension minus (-) 1/2". This allows for a 1/4" minimum caulk joint at both the Head and Sill.

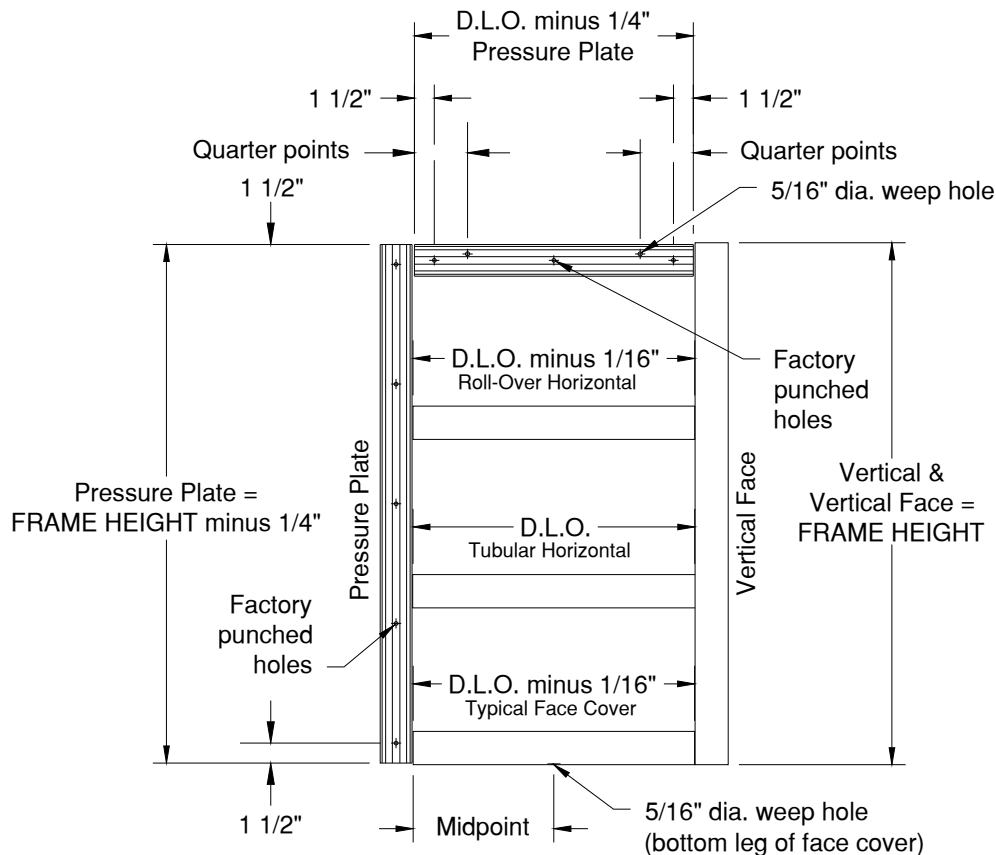

RELIANCE™ - TC LT Curtain Wall Installation and Glazing Manual

4.0 Cut Members to Size

Vertical Members

AW-132 Glazing AdaptorD.L.O plus (+) 3/4"

CW-823, WW-220, WW-221 Corner Mullion Extension Frame Height

RL-216 Face Cap

RL-113, RL-114 Corner Face Cap

RL-124 Pocket Filler @ Jamb

RL-220, RL-221, RL-222 Corner Extension

RL-233, RL-270 Corner Mullion

RL-404, RL-504 SSG Mullion

RL-420, RL-520 Mullion

RL-430, RL-530 Heavy Mullion

WW-230, WW-240, WW-241 Corner Mullion

RL-122, RL-124 Pocket Filler @ Doors D.H.O plus (+) 1-1/2"

RL-124 Pocket Filler @ VentsD.L.O plus (+) 1"

RL-131, RL-135 Glazing Adaptor

RL-142 SSG to Captured Adaptor

RL-125 Pocket Filler @ Vents

WW-133, WW-135, WW-136, WW-145 Glazing Adaptor

RL-162-03, RL-163-03 Pressure Plate Frame Height minus (-) 1/4"

RL-164, RL-165 Corner Pressure Plate

Horizontal Framing Members

Without Corners

AW-132 Glazing Adaptor D.L.O minus (-) 1/4"

RL-162-03, RL-163-03 Pressure Plate @ Captured Verticals

RL-216 Face Cap @ Captured Verticals..... D.L.O minus (-) 1/16"

RL-122, RL-125 Pocket Filler

RL-425, RL-525 Horizontals (Rollover)

WW-236, WW-237 Filler

RL-216 Face Cap @ SSG Verticals D.L.O. plus (+) 7/8" per SSG Mullion
minus (-) 1/32" per Captured Mullion

RL-135 Glazing Adaptor D.L.O minus (-) 1/32"

RL-162-03, RL-163-03 Pressure Plate @ SSG Verticals ... D.L.O. plus (+) 3/4" per SSG Mullion
minus (-) 1/8" per Captured Mullion

RL-257, WW-258 Expansion Gasket Retainer (Typical)D.L.O plus (+) 1-3/4"

RL-257, WW-258 Expansion Gasket Retainer (Jamb to Int Mull).....D.L.O plus (+) 2-7/8"

RL-257, WW-258 Expansion Gasket Retainer (Jamb to Jamb).....D.L.O plus (+) 4"

RELIANCE™ - TC LT Curtain Wall Installation and Glazing Manual

RL-420, RL-520 Horizontals (Tubular) D.L.O
RL-535, WW-484, WW-584 Expansion Horizontal

WW-259 Expansion Horizontal Trim Frame Width minus (-) 1/8"

Inside 90° Corners

RL-257, WW-258 Expansion Gasket Retainer (Typical) D.L.O plus (+) 9/16"
RL-257, WW-258 Expansion Gasket Retainer (Jamb to Int Mull)

RL-420 Horizontal (Tubular) D.L.O plus (+) 4"
RL-425 Horizontals (Rollover)
WW-484 Expansion Horizontal

RL-520 Horizontal (Tubular) D.L.O plus (+) 5-1/4"
RL-525 Horizontals (Rollover)
RL-535, WW-584 Expansion Horizontal

WW-236 Filler D.L.O plus (+) 3-15/16"

WW-237 Filler D.L.O plus (+) 5-3/16"

Outside 90° Corners

RL-162-03, RL-163-03 @ SSG Corners..... D.L.O. plus (+) 7/8" per SSG Mullion
RL-216 @ SSG Corners minus (-) 1/32" per Captured Mullion

RL-257, WW-258 Expansion Gasket Retainer (Typical) D.L.O plus (+) 2-7/16"
RL-257, WW-258 Expansion Gasket Retainer (Jamb to Int Mull)

Outside 135° Corners

RL-257, WW-258 Expansion Gasket Retainer (Typical) D.L.O plus (+) 1-1/2"
RL-257, WW-258 Expansion Gasket Retainer (Jamb to Int Mull)

Accessories

Verticals

GP-191 Isolator Gasket..... Frame Height plus (+) 1/4" per foot

GP-103, GP-117, GP-118, GP-146 Fixed Gasket..... D.L.O plus (+) 1"
GP-106, GP-145 SSG Spacer Gasket plus (+) 1/4" per foot

GP-103, GP-117, GP-118 Fixed Gasket @ Pressure Plate Pressure Plate Length
plus (+) 1/4" per foot

Horizontals

GP-103, GP-117, GP-118 Fixed Gasket..... D.L.O plus (+) 1/4" per foot
GP-191 Isolator Gasket

GP-103, GP-117, GP-118 Fixed Gasket @ Pressure Plate..... Pressure Plate Length
plus (+) 1/4" per foot

GP-144 Expansion Gasket Frame Width minus (-) 8"
plus (+) 1/4" per foot

RELIANCE™ - TC LT Curtain Wall Installation and Glazing Manual

Other Members (as Required)

Door Subframe (Jambs)	D.O.H. plus (+) 3/4"
Flush Door Pressure Plate (Jambs)	
Flush Door Pressure Plate (Jambs)	
Door Subframe (Header).....	D.O.W. minus (-) 1/32"
Flush Door Pressure Plate (Header)	D.O.W. minus (-) 1/16"
Flush Door Face Cover (Header)	
Flush Door Face Cover (Jambs)	D.O.H. plus (+) 2"

Abbreviations used within these instructions:

D.L.O. = Day Light Opening

D.O.H. = Door Opening Height

D.O.W. = Door Opening Width

Ø = Diameter

RELIANCE™ - TC LT Curtain Wall Installation and Glazing Manual

5.0 Vertical Fabrication

- 5.1 Fabricate vertical mullions for horizontal members, using **DJ-117** Drill Jig. Drill holes for shear block using holes marked "A" and "B". See *Figure 6*. When working off horizontal centerlines, use the slot milled into the drill jig to align the jig with the centerline.
- 5.2 Fabricate corner mullions for horizontal members as shown in *Figure 7*.
- 5.3 When using "F" anchors, fabricate the jambs as shown in
- 5.4 *Figure 8*.
- 5.5 Fabricate vertical accessories, such as, glazing adaptors and pocket fillers as shown in *Figure 9* and *Figure 10*.

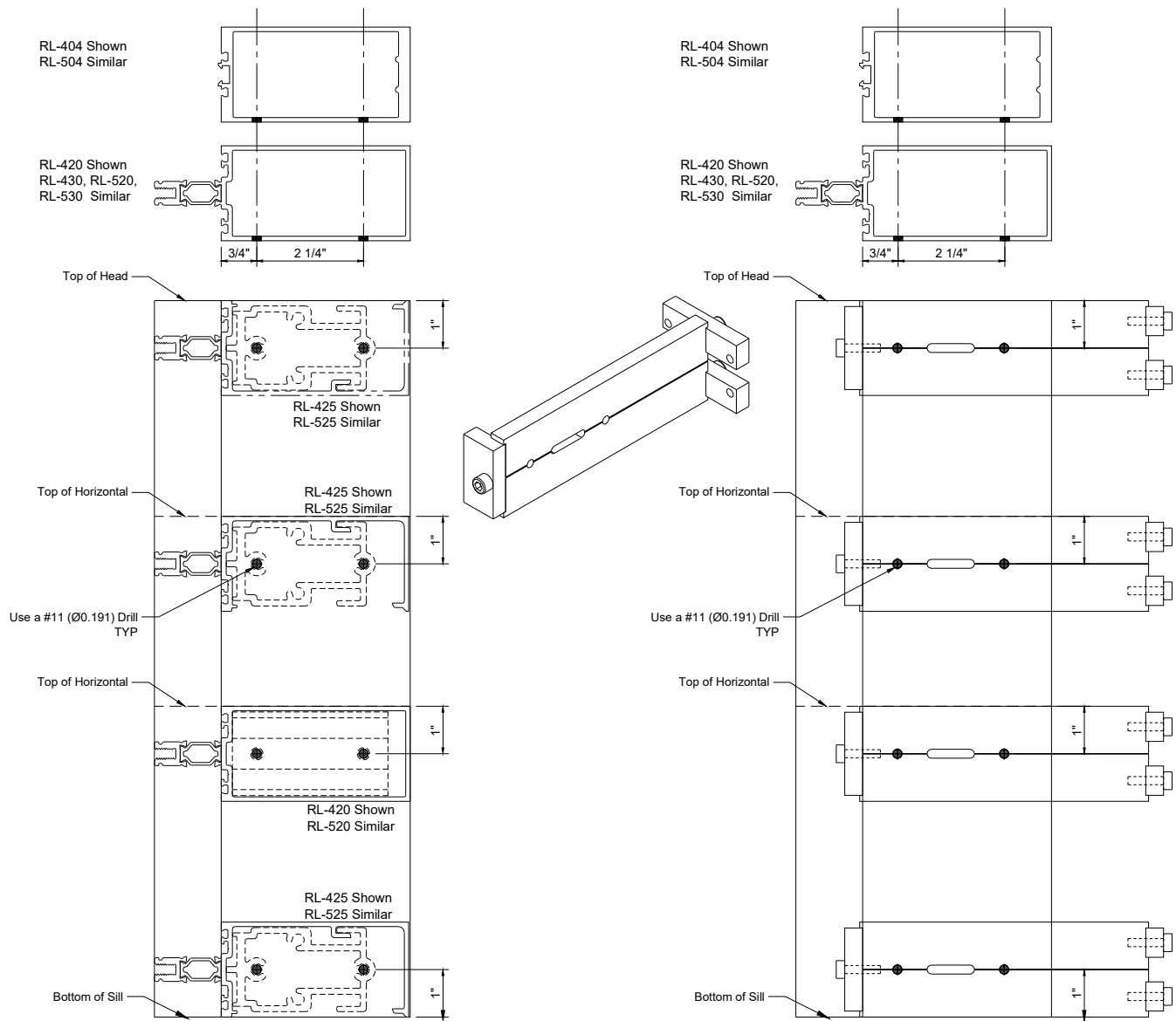

Figure 6: Vertical Mullion Fabrication

RELIANCE™ - TC LT Curtain Wall Installation and Glazing Manual

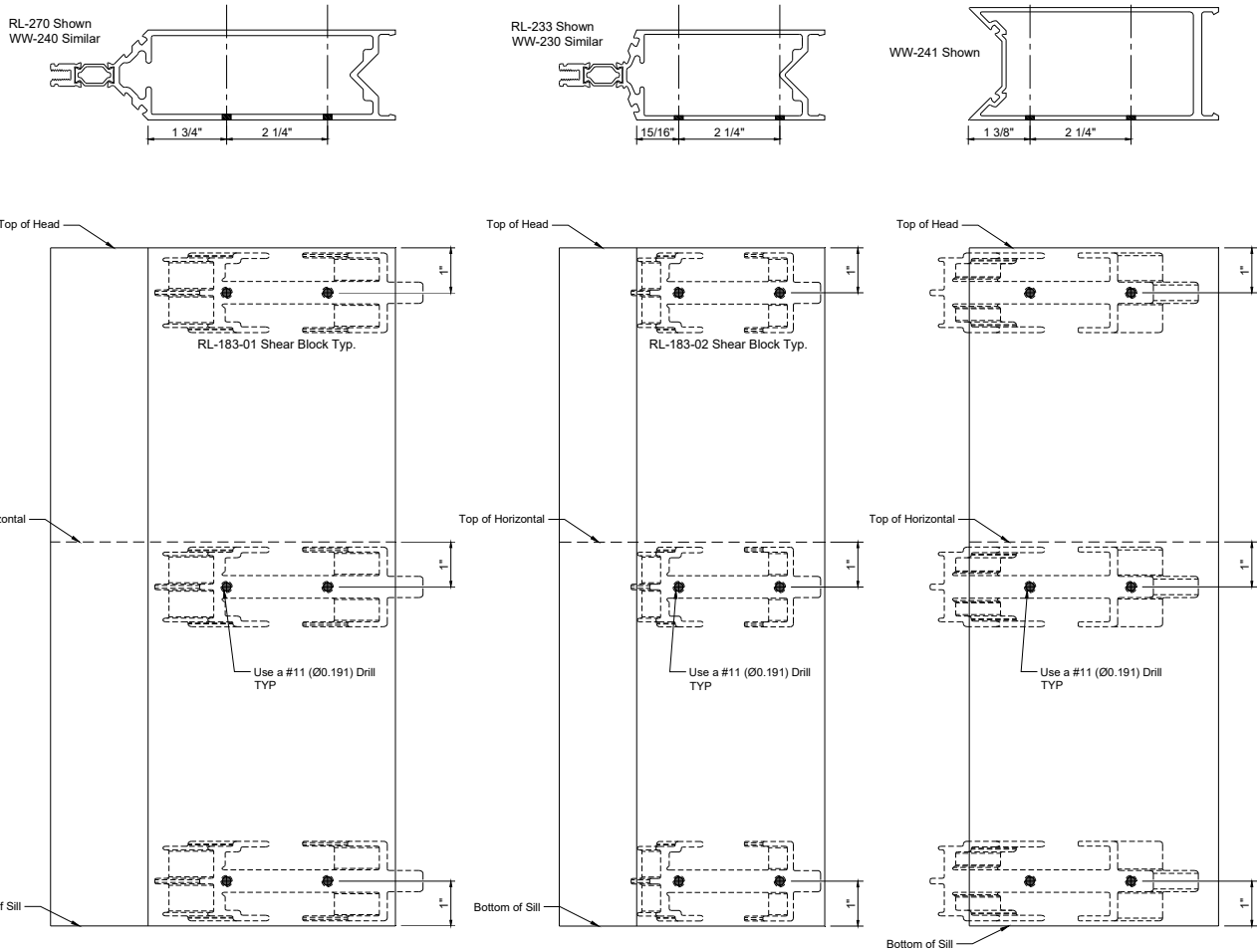

Figure 7: Corner Mullion Fabrication

RELIANCE™ - TC LT Curtain Wall Installation and Glazing Manual

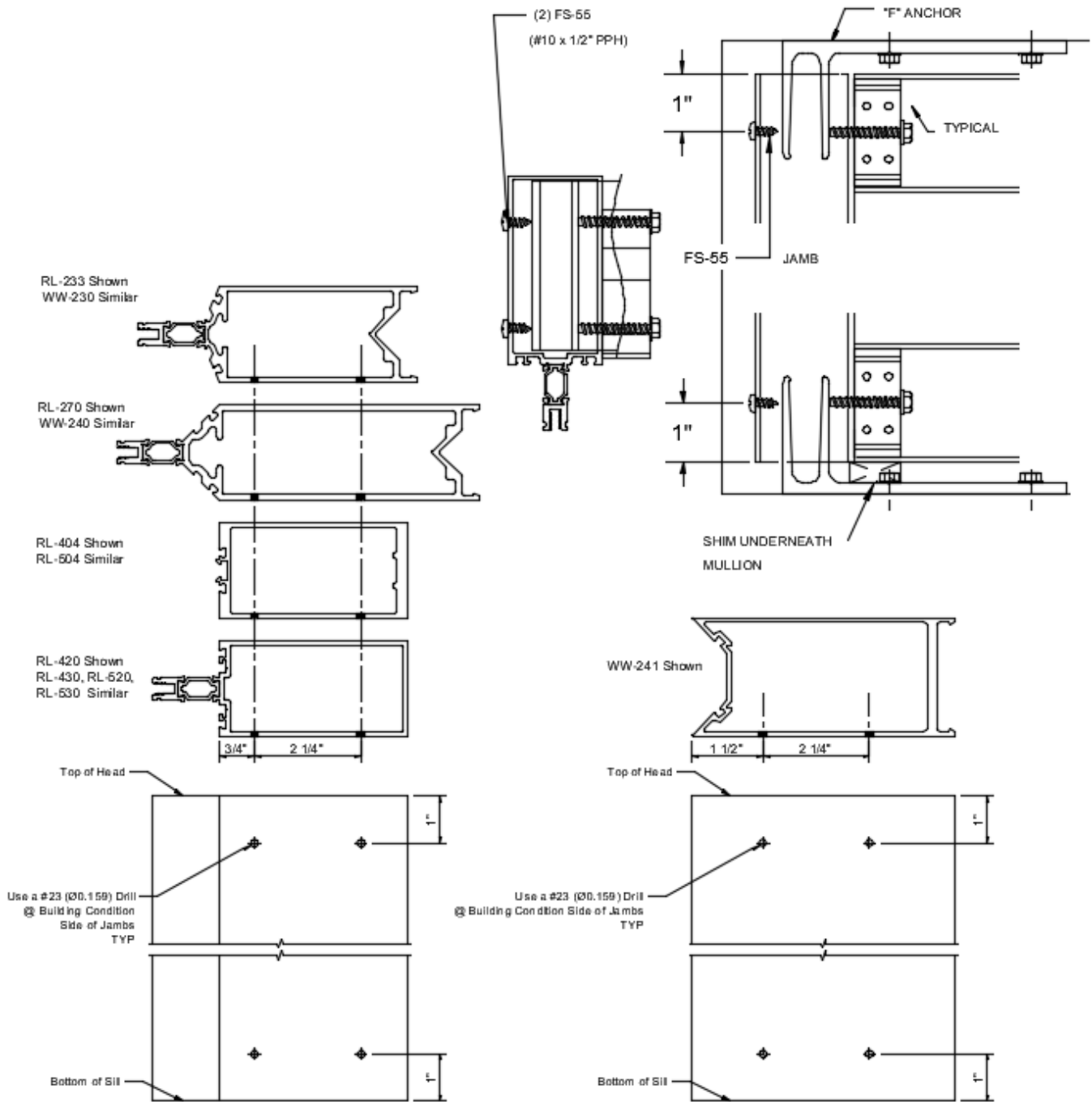

Figure 8: Vertical Jamb Fabrication at "F" Anchors

1-866-OLDCASTLE (653-2278)

OBE.com

Version: 2023-1013

Copyright © 2023 Oldcastle BuildingEnvelope®
All rights reserved.

™ © Trademarks of Oldcastle BuildingEnvelope and its affiliated companies or respective owners.

RELIANCE™ - TC LT Curtain Wall Installation and Glazing Manual

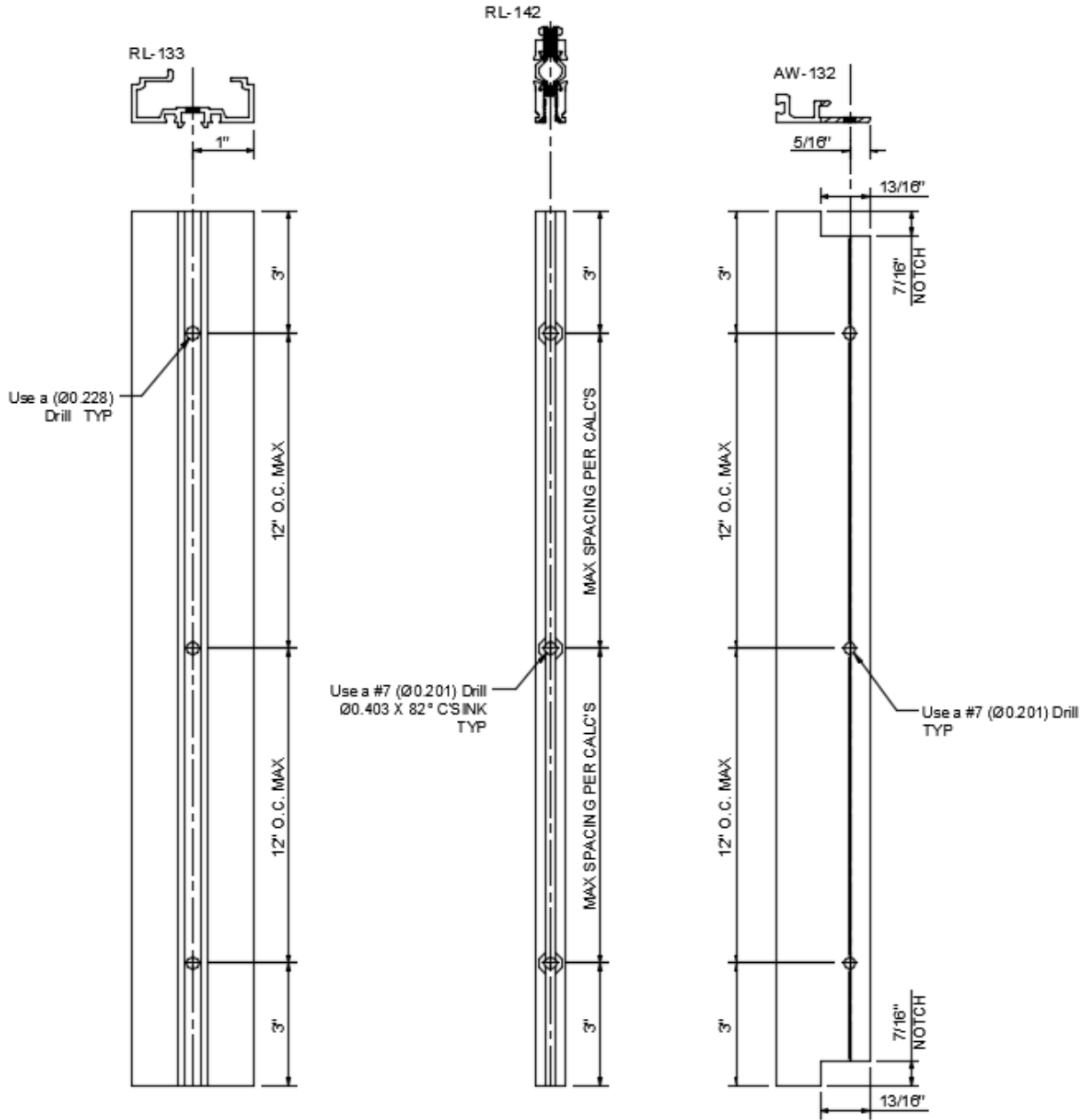

Figure 9: Vertical Accessory Fabrication

RELIANCE™ - TC LT Curtain Wall Installation and Glazing Manual

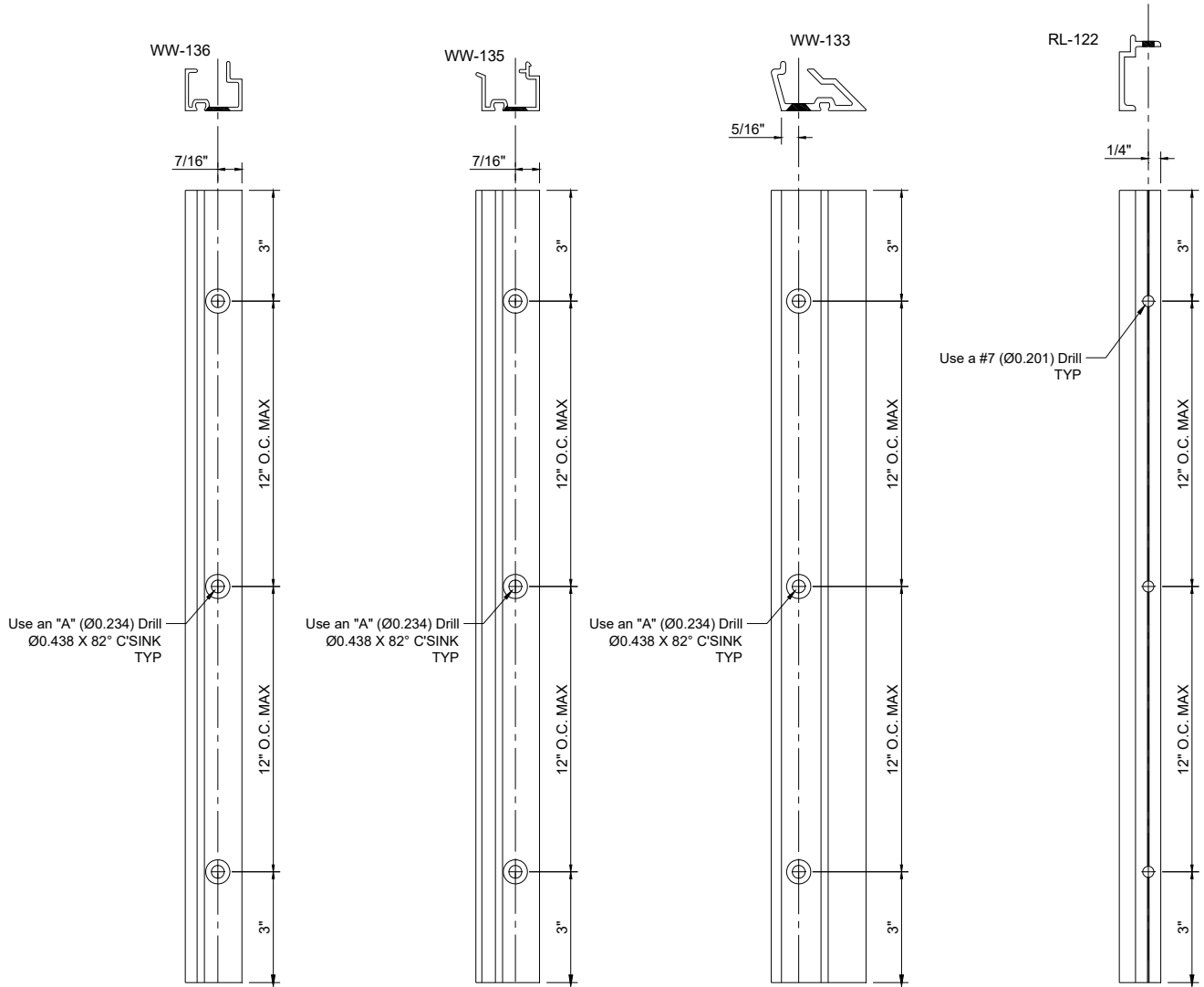

Figure 10: Vertical Accessory Fabrication

RELIANCE™ - TC LT Curtain Wall Installation and Glazing Manual

6.0 Vertical Fabrication at Expansion Horizontal

- 6.1 Fabricate Vertical Mullions for horizontal members. Drill holes for shear block per *Figure 11* and *Figure 12*.
- 6.2 Fabricate **RL-164** Pressure Plate at **GP-144** Expansion Gasket per *Figure 13*.

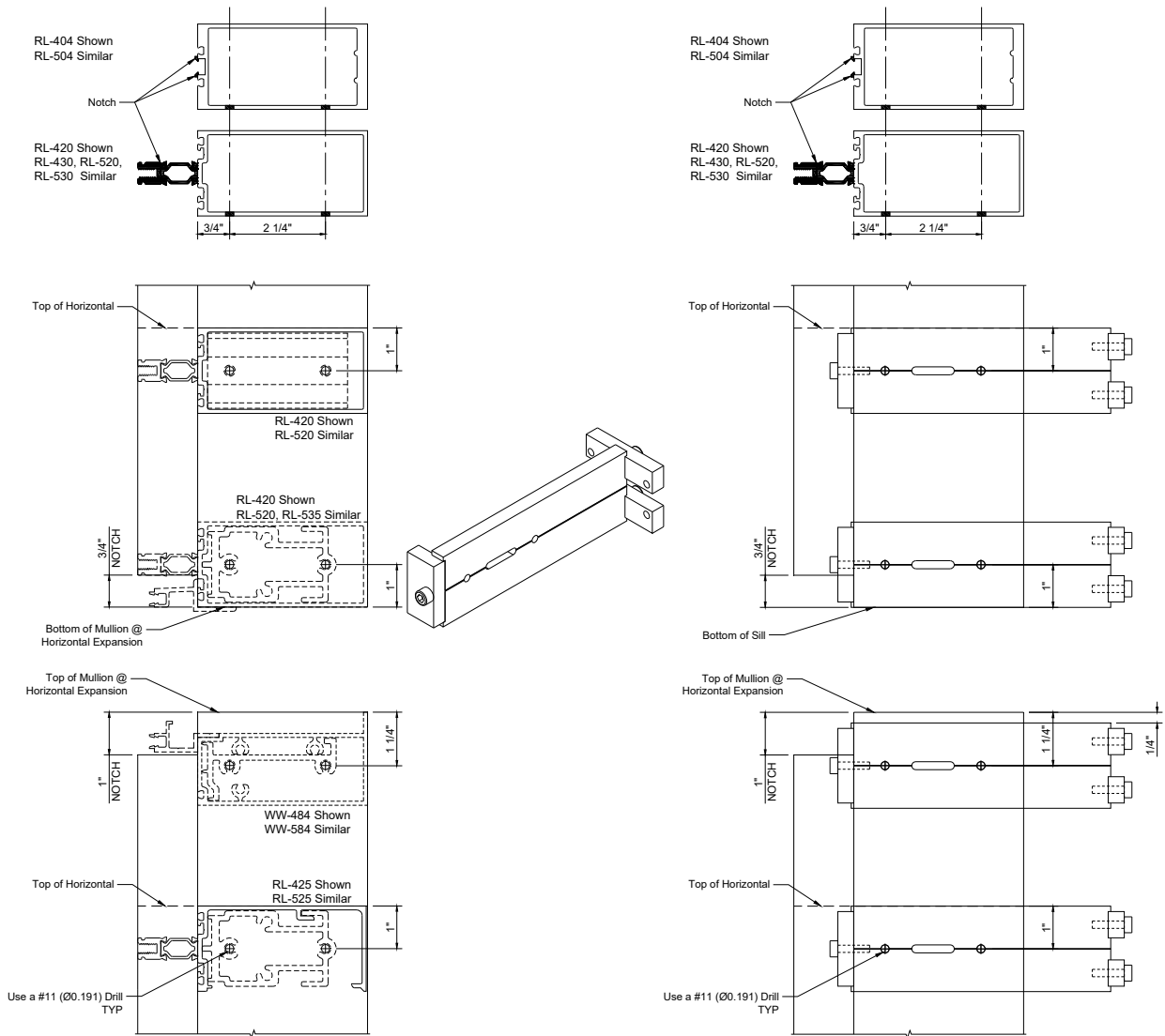

Figure 11: Vertical Fabrication at Expansion Horizontal

RELIANCE™ - TC LT Curtain Wall Installation and Glazing Manual

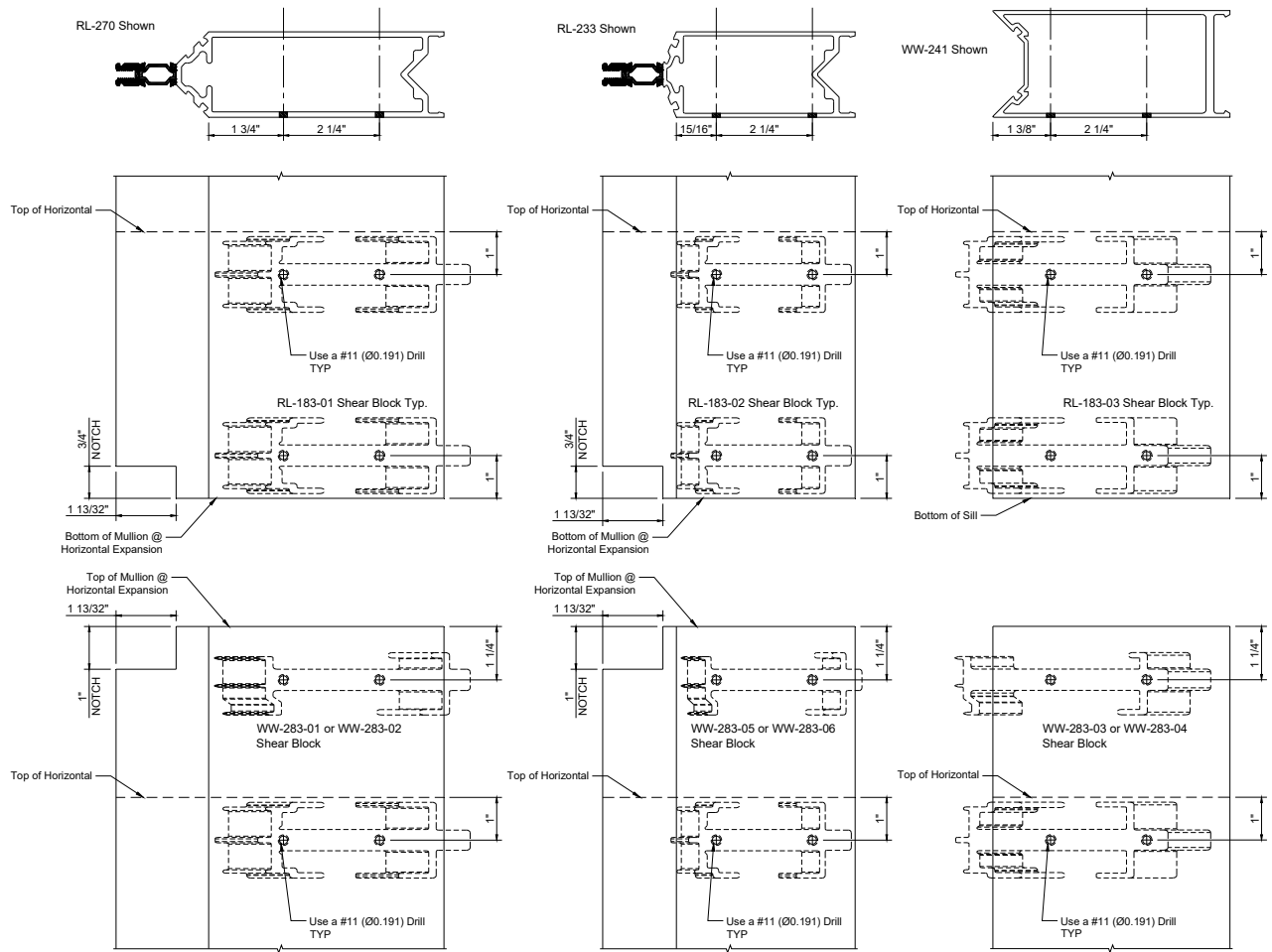

Figure 12: Corner Fabrication at Expansion Horizontal

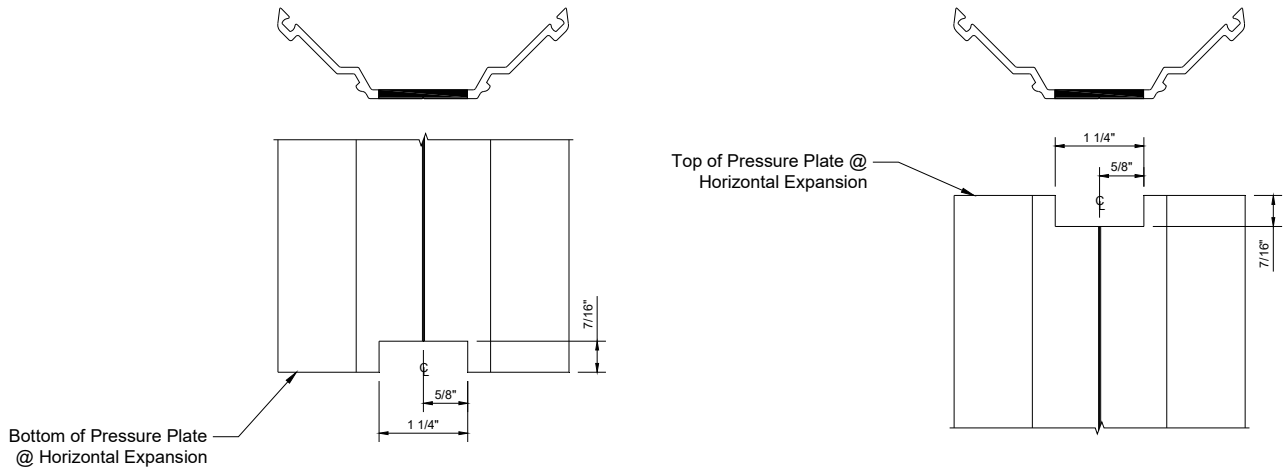

Figure 13: RL-164 Pressure Plate Fabrication at Expansion Horizontal

RELIANCE™ - TC LT Curtain Wall Installation and Glazing Manual

7.0 Horizontal Fabrication

- 7.1 Fabricate each end of the horizontal members for shear block fasteners, using **DJ-117** Drill Jig. See *Figure 14*.
Note: When fabricating tubular (one-piece) horizontals, use the side of the drill jig stamped "Horizontal". When fabricating head, sill and roll-over horizontals, use the side stamped "Head/Sill/Rollover".
- 7.2 When using tubular horizontals, both ends of the horizontal members must be notched on the last installed bay. Reference *Figure 15*.
- 7.3 Fabricate horizontals as required at arrow corners per *Figure 16*, *Figure 17*, and *Figure 18*.
- 7.4 Fabricate horizontal pocket fillers per *Figure 19* as required.

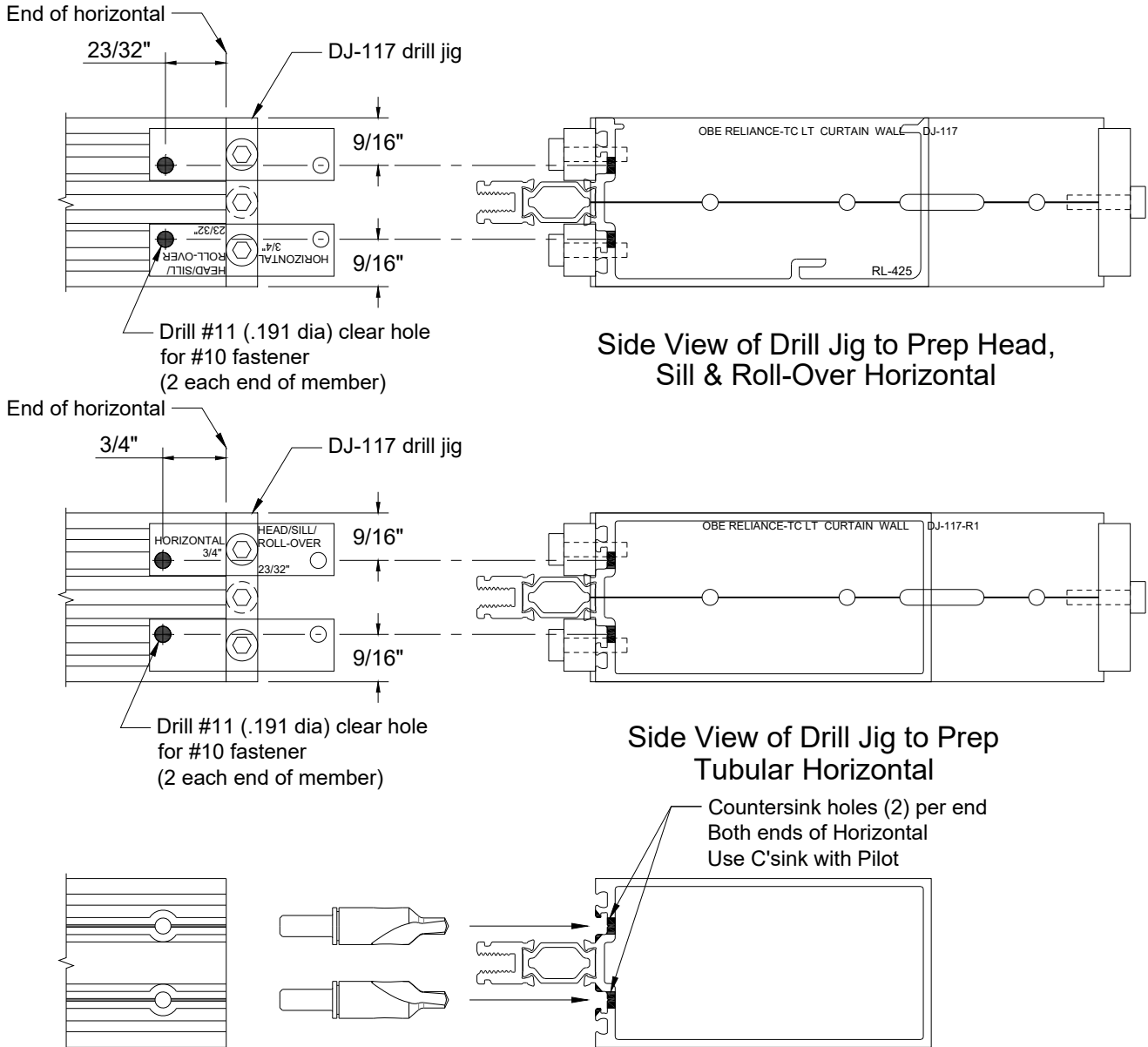

Figure 14: Horizontal Fabrication

RELIANCE™ - TC LT Curtain Wall Installation and Glazing Manual

RL-420 Shown
RL-520 Similar

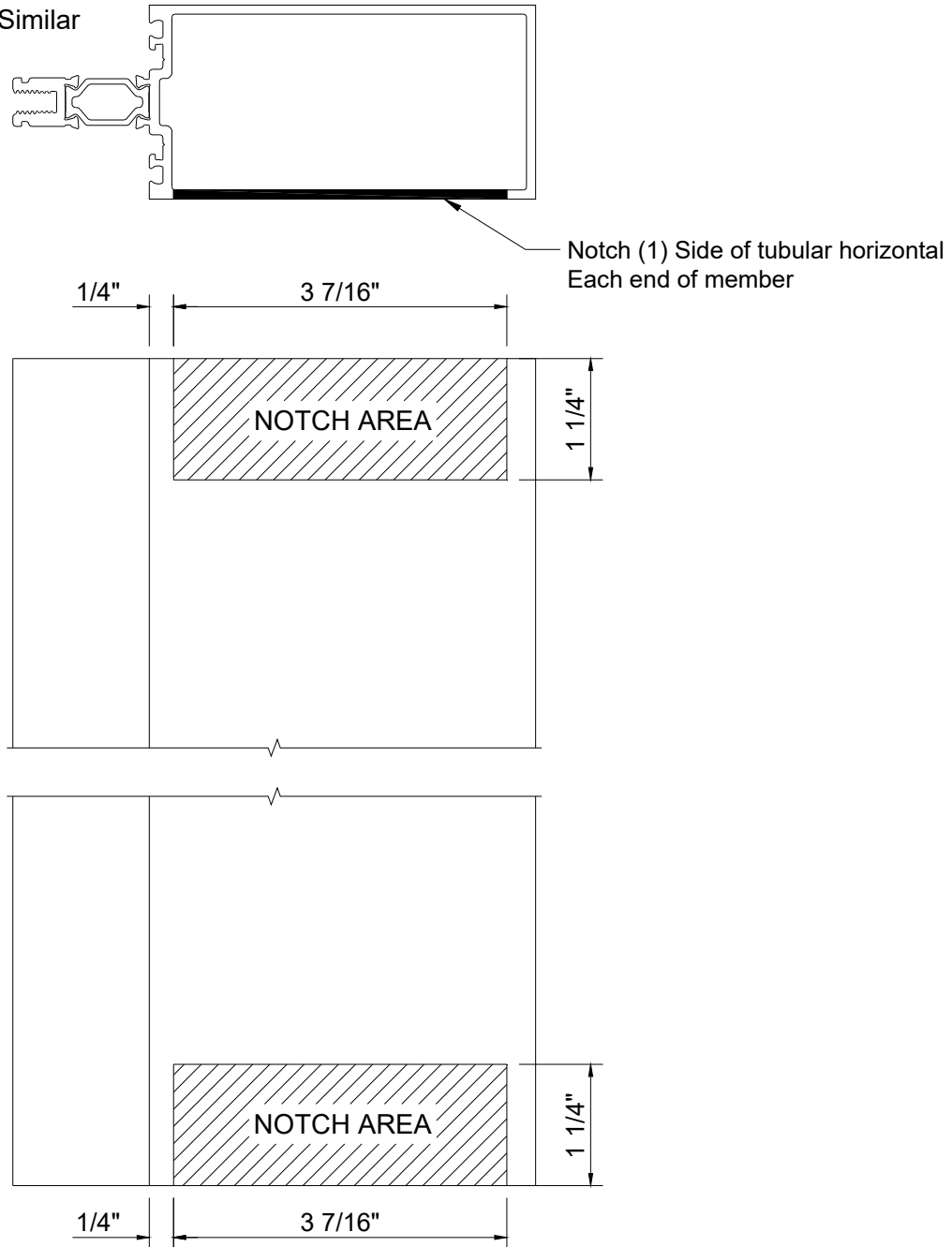

Figure 15: Tubular Horizontal Notch Fabrication

RELIANCE™ - TC LT Curtain Wall Installation and Glazing Manual

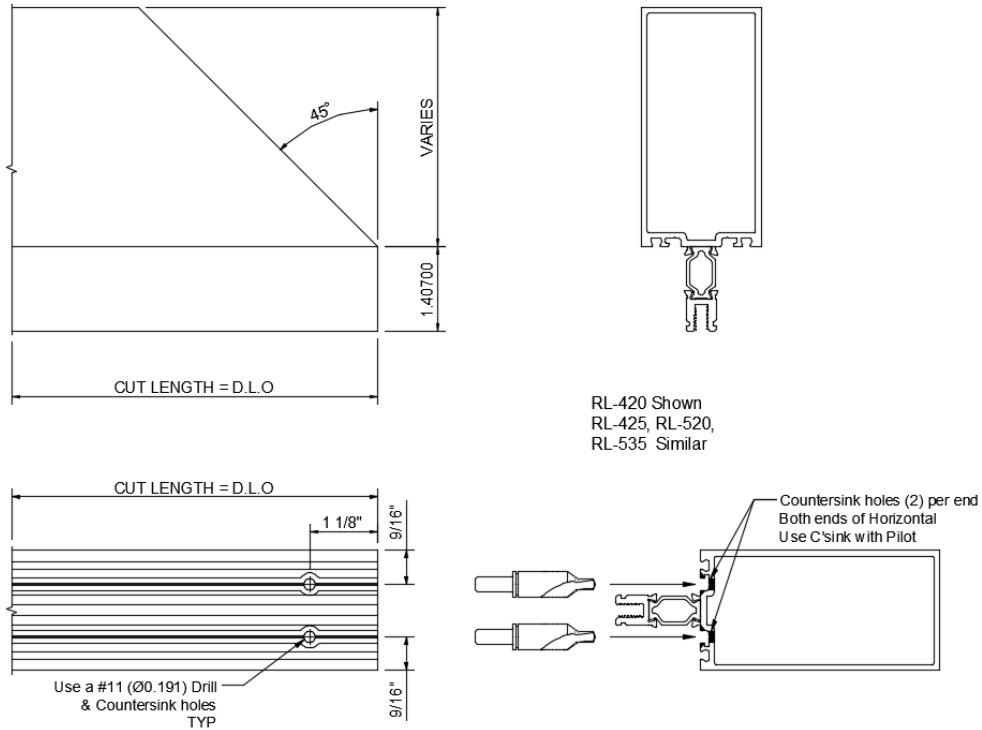

Figure 16: Horizontal at 90° Outside Corner

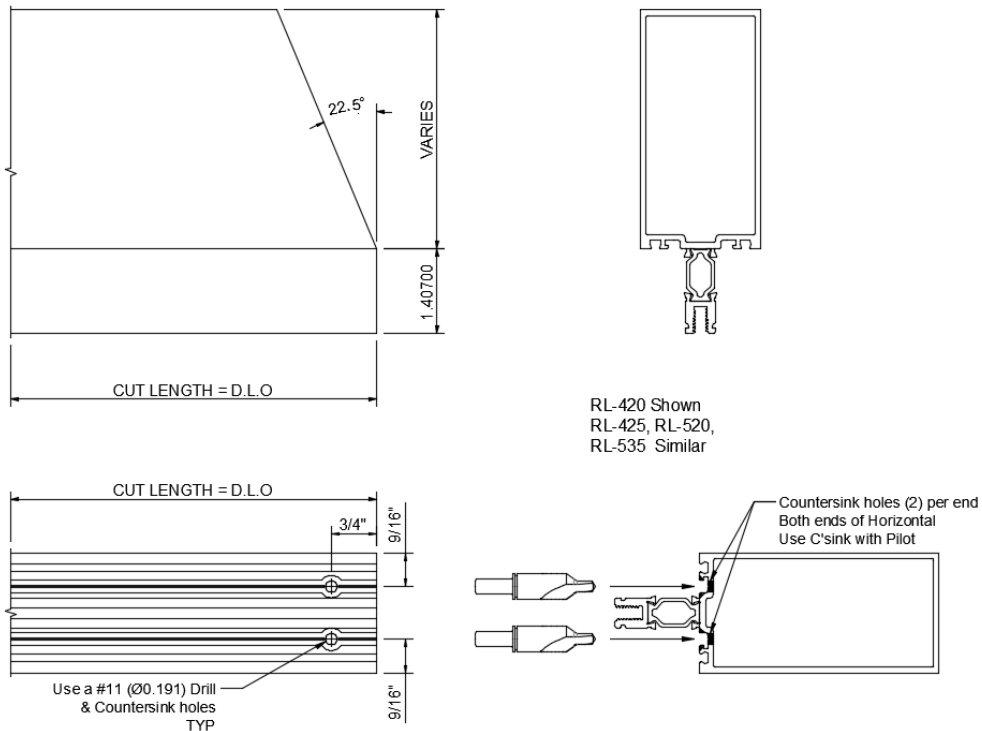

Figure 17: Horizontal at 135° Outside Corner

RELIANCE™ - TC LT Curtain Wall Installation and Glazing Manual

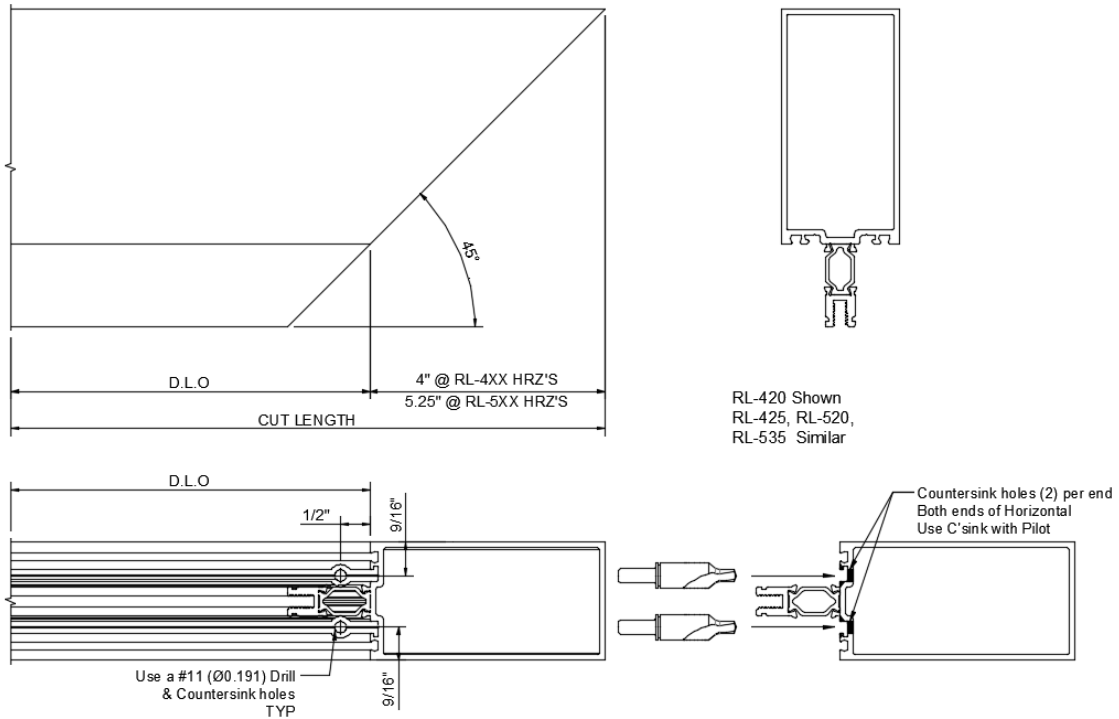

Figure 18: Horizontal at 90° Inside Corner

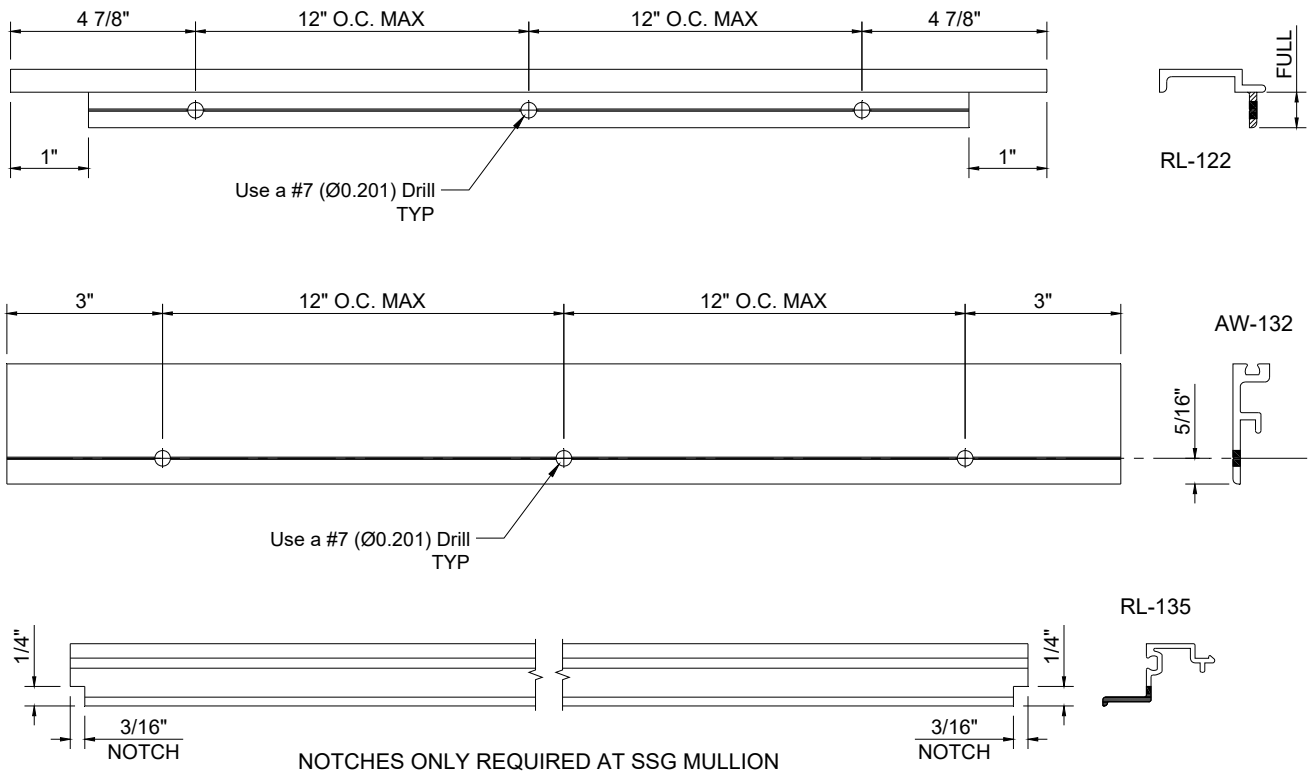

Figure 19: Horizontal Pocket Filler Fabrication

1-866-OLDCASTLE (653-2278)

OBE.com

Version: 2023-1013

Copyright © 2023 Oldcastle BuildingEnvelope®
All rights reserved.

™ ® Trademarks of Oldcastle BuildingEnvelope and its affiliated companies or respective owners.

RELIANCE™ - TC LT Curtain Wall Installation and Glazing Manual

Horizontal Fabrication at Expansion Horizontal

- 7.5 Fabricate each end of the horizontal expansion gasket retainers as shown in *Figure 20*.
- 7.6 Fabricate **RL-257** and **WW-258** at 90° outside corner as required per, *Figure 21*.
- 7.7 Fabricate **RL-257** and **WW-258** at 135° outside corner as required per, *Figure 22*.
- 7.8 Fabricate **RL-257** and **WW-258** at 90° inside corner as required per, *Figure 23*.
- 7.9 Fabricate optional **WW-259** expansion horizontal trim per *Figure 24*.

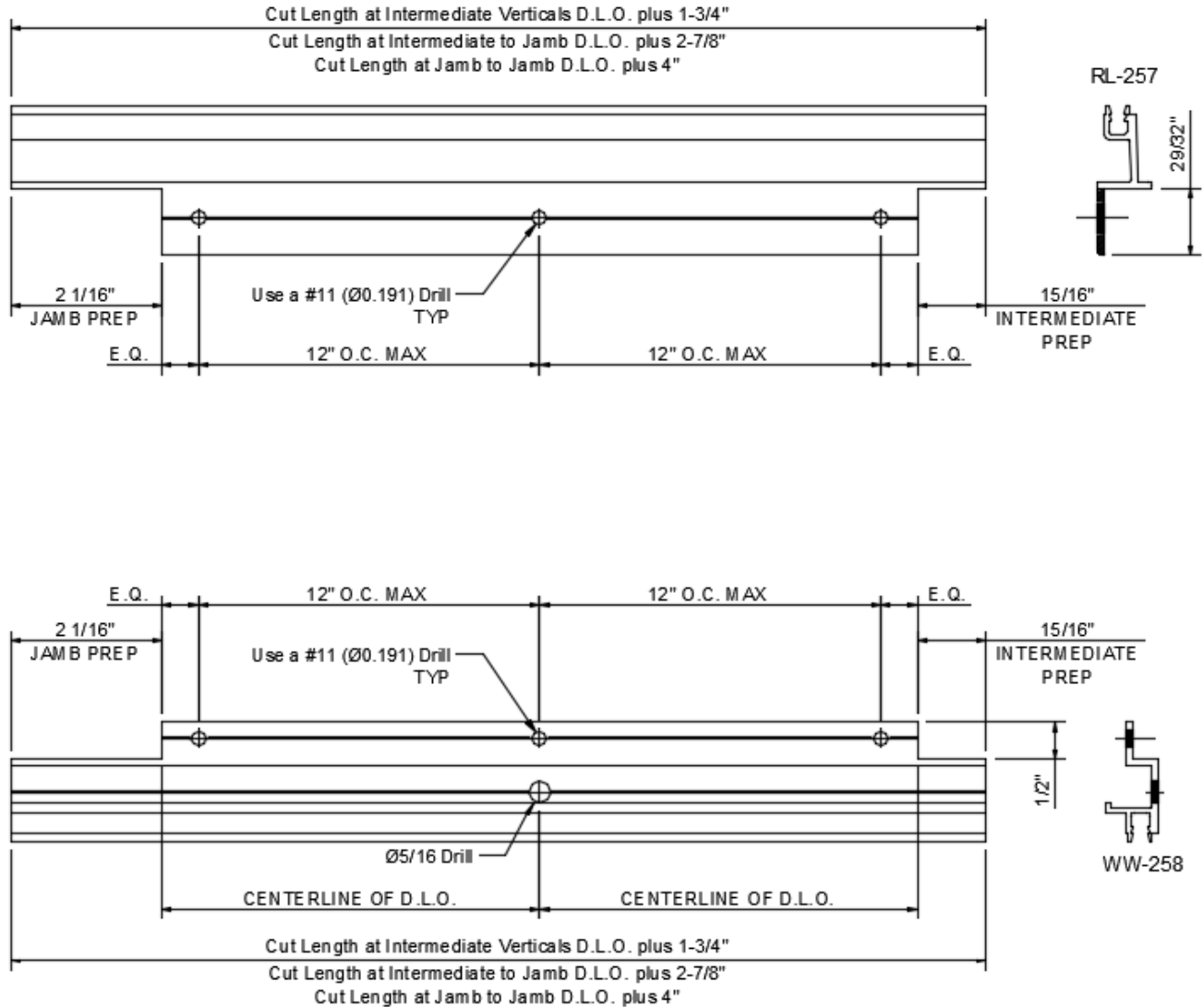

Figure 20: Horizontal Fabrication at Expansion Horizontal

RELIANCE™ - TC LT Curtain Wall Installation and Glazing Manual

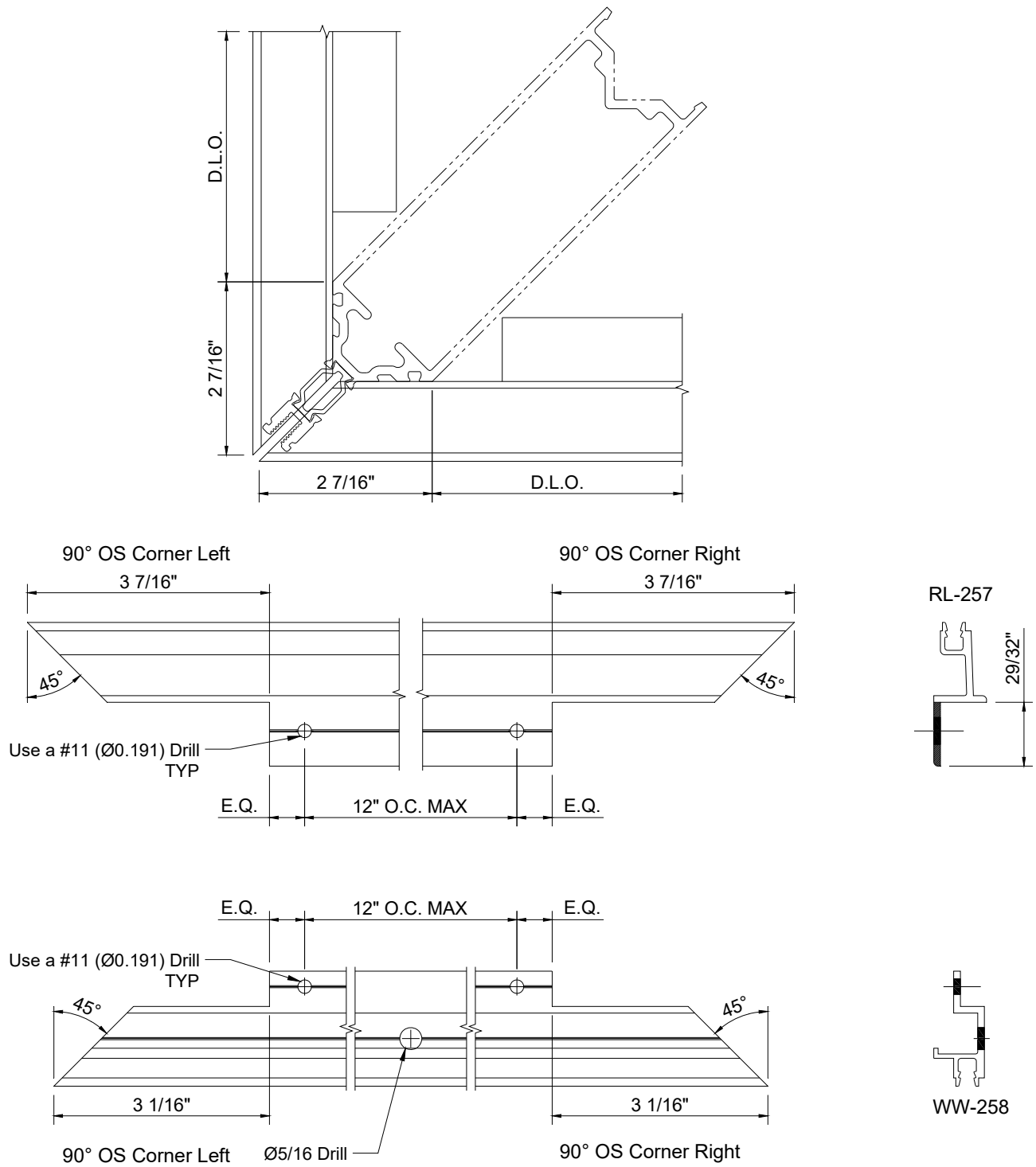

Figure 21: Horizontal Expansion Gasket Retainers at 90° Outside Corner

RELIANCE™ - TC LT Curtain Wall Installation and Glazing Manual

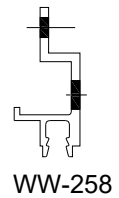
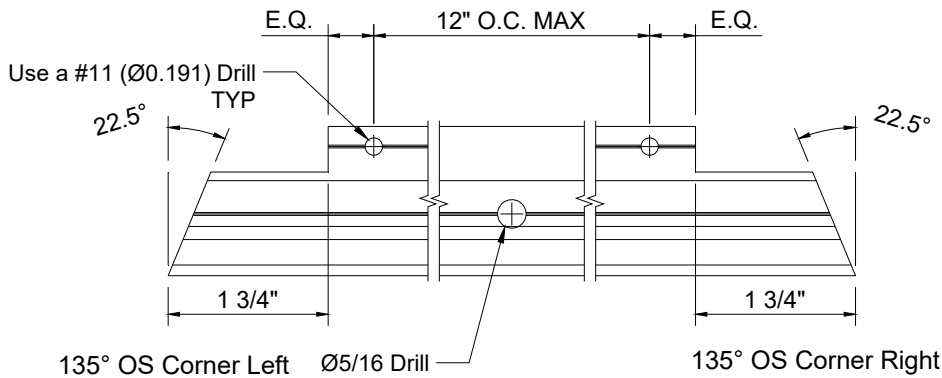
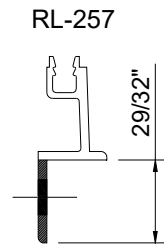
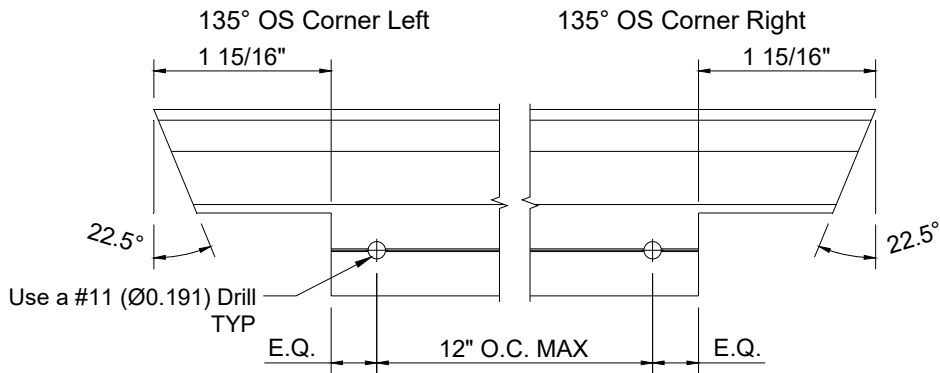
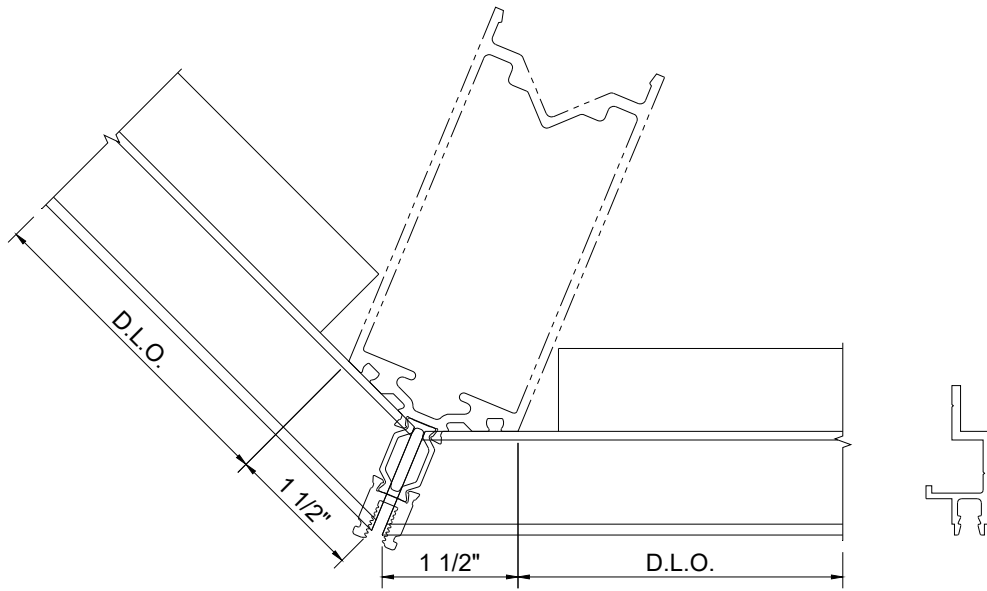

Figure 22: Horizontal Expansion Gasket Retainers at 135° Outside Corner

RELIANCE™ - TC LT Curtain Wall Installation and Glazing Manual

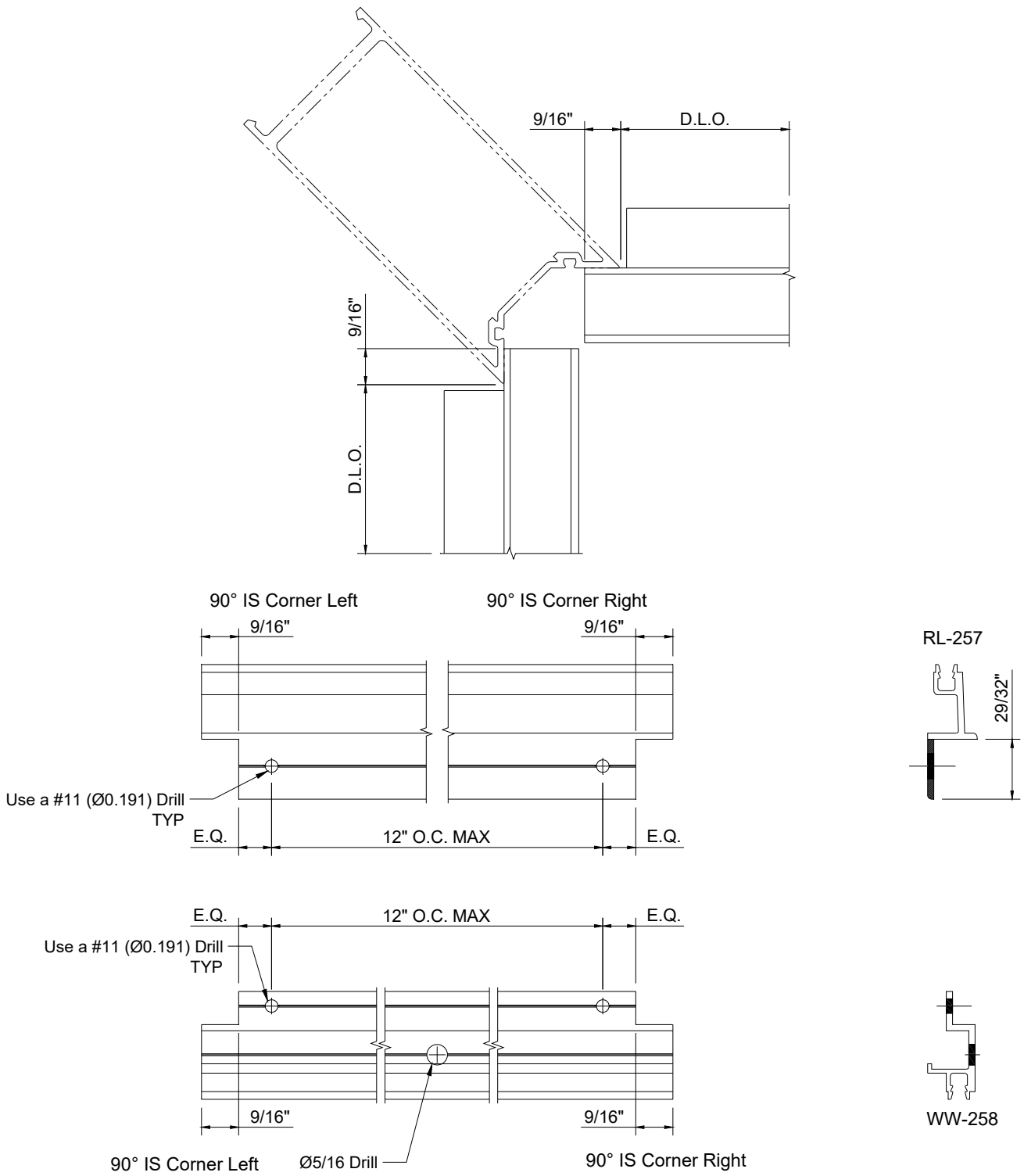

Figure 23: Horizontal Expansion Gasket Retainers at 90° Inside Corner

RELIANCE™ - TC LT Curtain Wall Installation and Glazing Manual

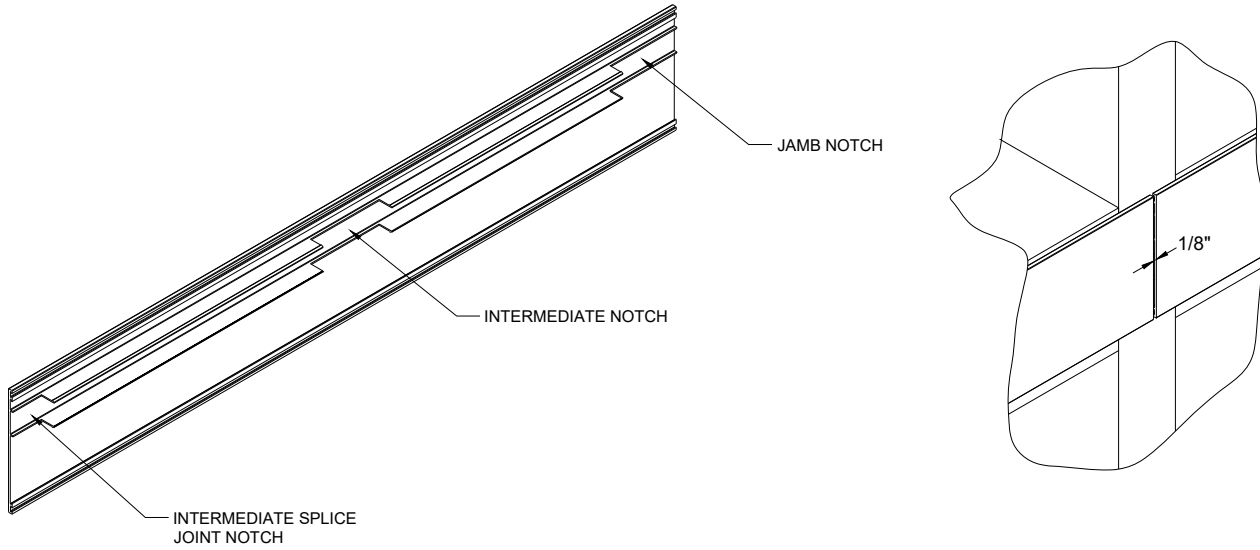
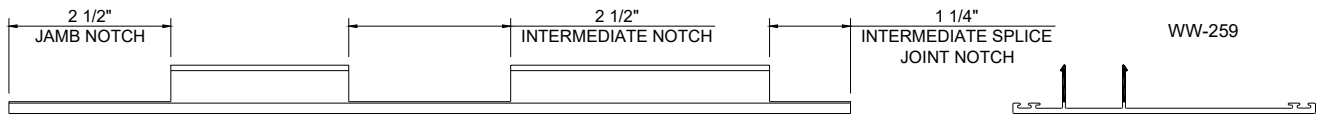

Figure 24: WW-259 Expansion Horizontal Trim Fabrication

RELIANCE™ - TC LT Curtain Wall Installation and Glazing Manual

8.0 Pressure Plate and Cover Fabrication

- 8.1 Drill 5/16" Ø weep holes at 1/4 points in the horizontal pressure plate.
- 8.2 Drill (1) 5/16" Ø weep hole at the bottom of each horizontal face cover at D.L.O. centerline. See *Figure 5* and *Figure 25*.
Note: For SSG applications, face covers typically run across mullions, so there will be multiple holes in each horizontal face cover.
- 8.3 All pressure plates have factory-punched holes for fasteners at 9" on center on **RL-162-03** and 8" on center on **RL-163-03**. To ensure proper pressure on the glazing, 0.266" Ø holes may need to be drilled at the ends of each horizontal pressure plate as required. Locate at 1-1/2" maximum from the ends. See *Figure 25*.

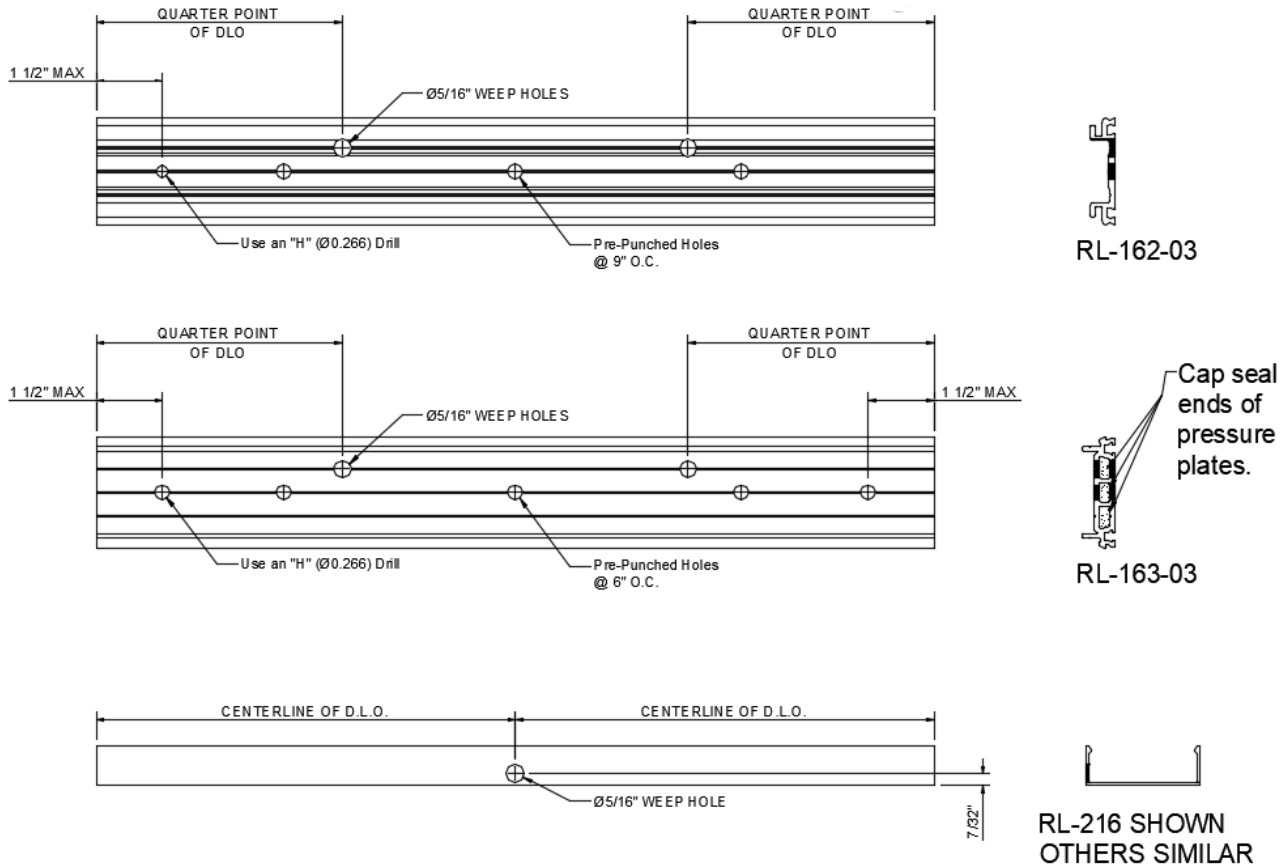

Figure 25: Pressure Plate and Cover Fabrication

RELIANCE™ - TC LT Curtain Wall Installation and Glazing Manual

9.0 Reinforcement

Figure 26 shows the typical attachment method for reinforcing in the Vertical Mullion. Refer to approved shop drawings for placement, size, and quantity of reinforcing required and means of attachment.

Refer to wind load charts in the detail catalog for single span and equal twin span conditions. For all other conditions such as unequal twin spans, knee brace, and multi-span conditions, contact your local Oldcastle BuildingEnvelope® facility for mullion reinforcing requirements or consult a qualified professional engineer.

NOTE: When using **RL-185-01** shear blocks, the shear blocks must be installed prior to fastening the reinforcement to the vertical mullions.

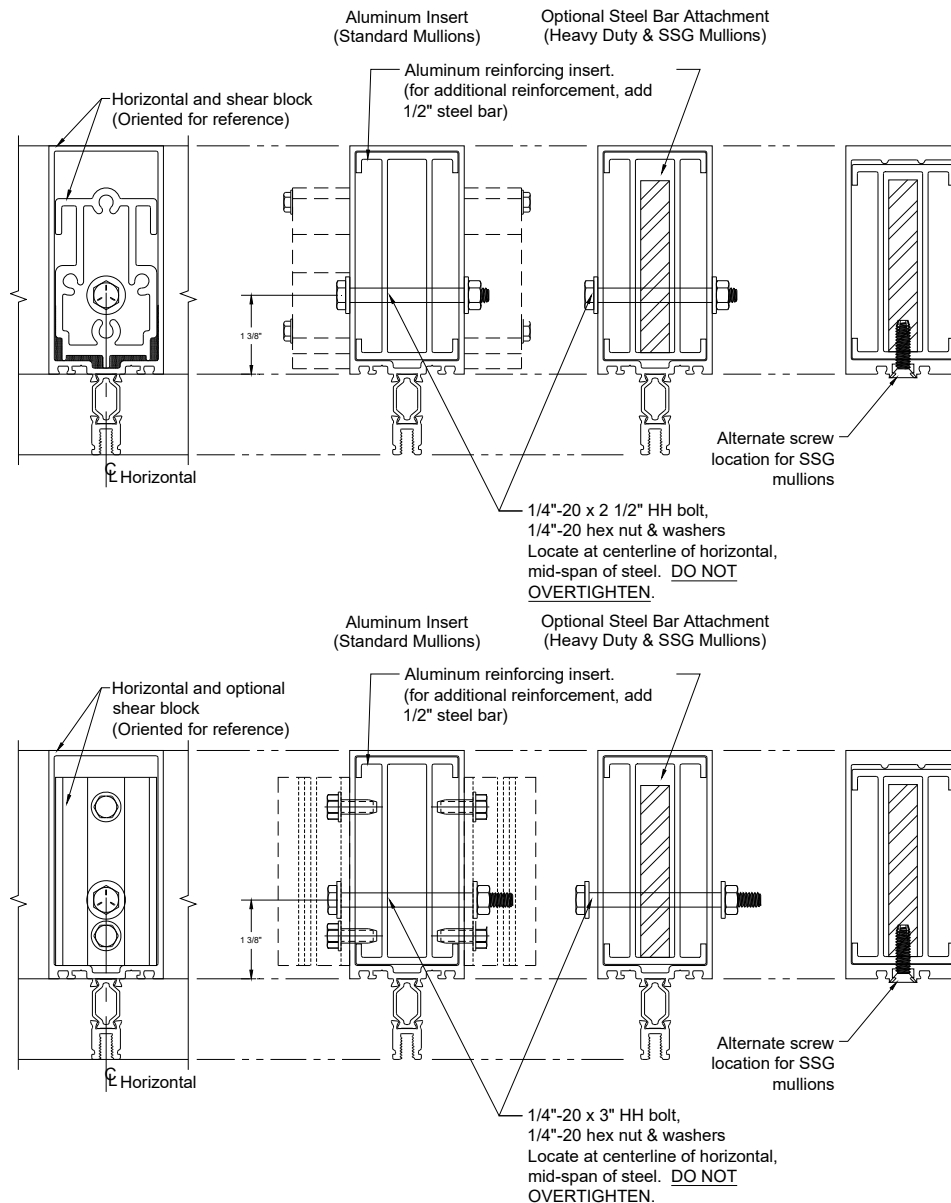

Figure 26: Typical Reinforcement Attachment

RELIANCE™ - TC LT Curtain Wall Installation and Glazing Manual

FRAME INSTALLATION AND ASSEMBLY

NOTE: Anchor type and sizes vary per job requirements. Details shown in these instructions are to be used as a guide only. Refer to approved shop drawings for actual conditions.

10.0 Vertical Member Assembly

Shear Block Attachment

- 10.1 Attach **RL-182-01** or **WW-276-01** Shear Blocks to Vertical using (2) **FS-9** Fasteners, see *Figure 27*.

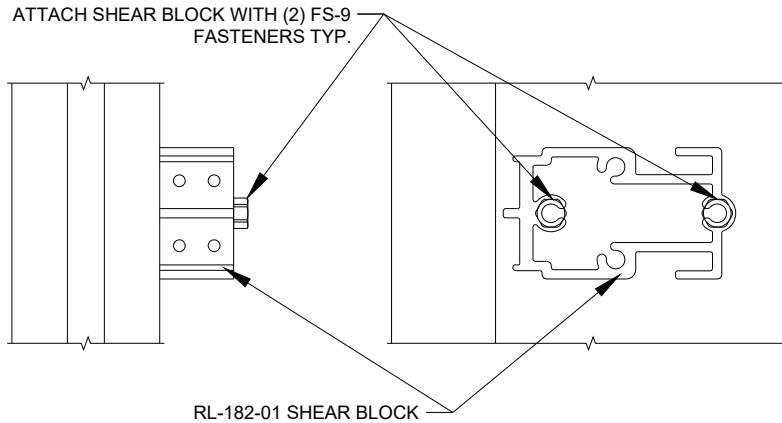

Figure 27: Standard Shear Block Attachment

- 10.2 If using the optional **RL-185-01** Shear Blocks, attached to the Vertical with (2) **FS-108** Fasteners, see *Figure 28*.

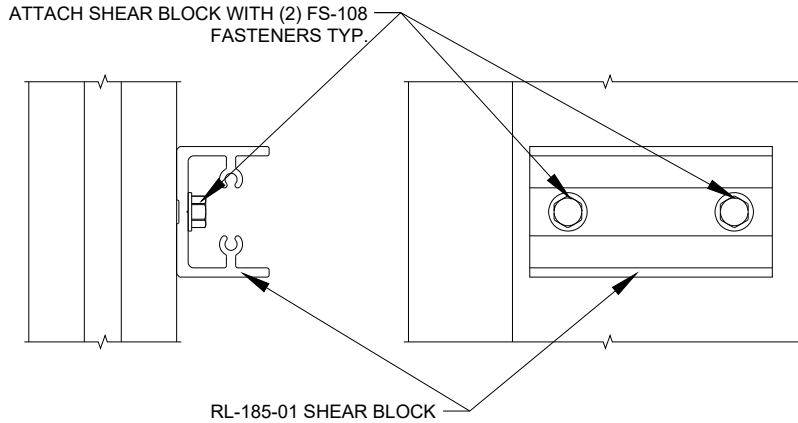

Figure 28: Optional Shear Block Attachment

- 10.3 When using one piece corner mullions, attach **RL-183-01** or **WW-283-02** (at 90° Outside Corner), **RL-183-02** (at 135° Outside Corner), or **RL-183-03** or **WW-283-03** (at 90° Inside Corner) Shear Blocks with (2) **FS-9** Fasteners, see *Figure 29*.

RELIANCE™ - TC LT Curtain Wall Installation and Glazing Manual

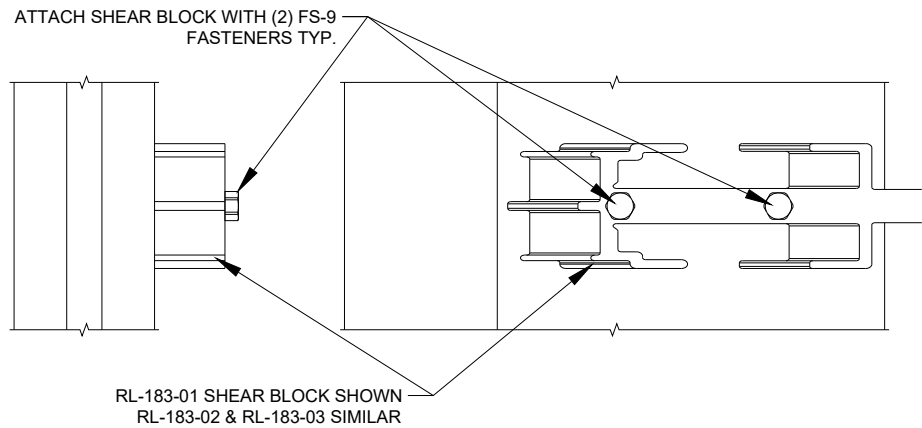

Figure 29: Shear Block Attachment at One-Piece Corners

- 10.4 If using **WW-104-02** Shear Block anchors (*Single and Twin Span Installation Only*), attach anchors and standard **RL-182-01** Shear Blocks to Vertical using **FS-9** Fasteners, see *Figure 30*. **NOTE:** Depending on the end reaction, either the shear block anchor or "F" and "T" anchors can be used to anchor the wall. When using the **WW-104-02** Shear Block anchor at Head and Sill, the **MAXIMUM** load is 375 lbs. per anchor (750 lbs. with anchor on both side of mullion). These capacities are based on proper design for anchor fastener to surrounding building condition.

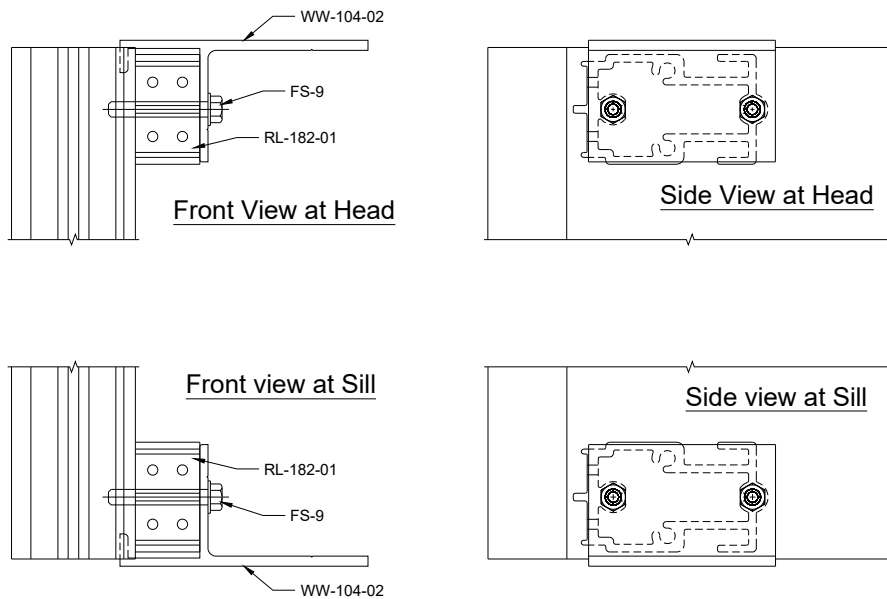

Figure 30: WW-104-02 Shear Block Anchor Attachment

RELIANCE™ - TC LT Curtain Wall Installation and Glazing Manual

"F" Anchor Auxiliary Fastener Installation

10.5 When using "F" anchors at the jamb condition add **FS-55** Fasteners to the Verticals at the Head and Sill, see *Figure 31*.

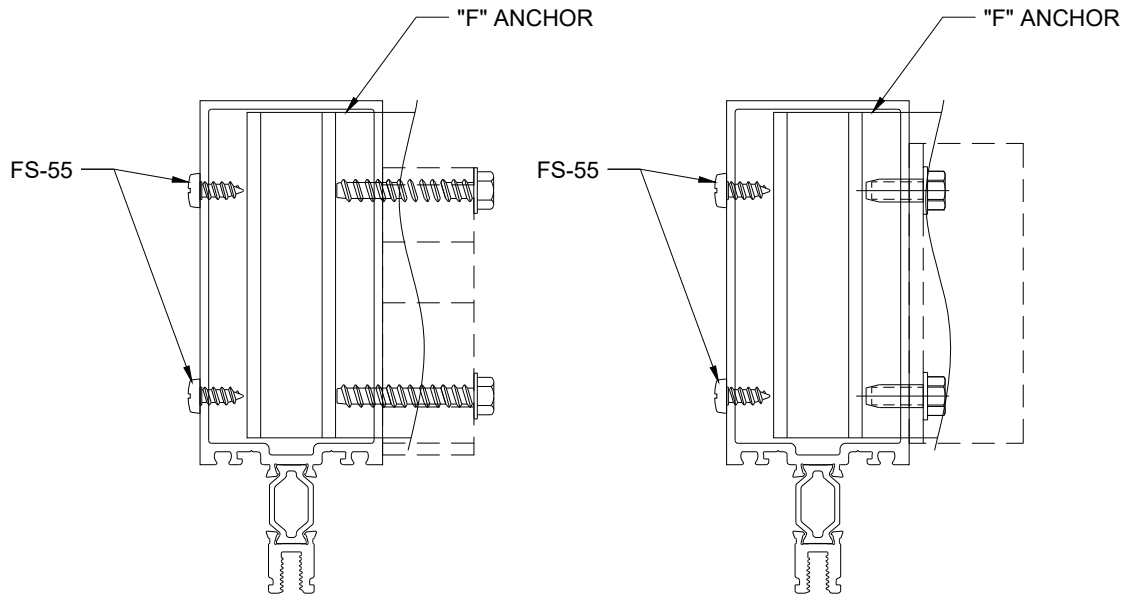

Figure 31: FS-55 at "F" Anchor Head and Sill

Pocket Filler Attachment

10.6 Insert **RL-124** Pocket Filler into gasket reglet and rotate to lock in place. See *Figure 32*.

10.7 Run a continuous line of sealant the full length of **RL-124**, as shown in *Figure 32*.

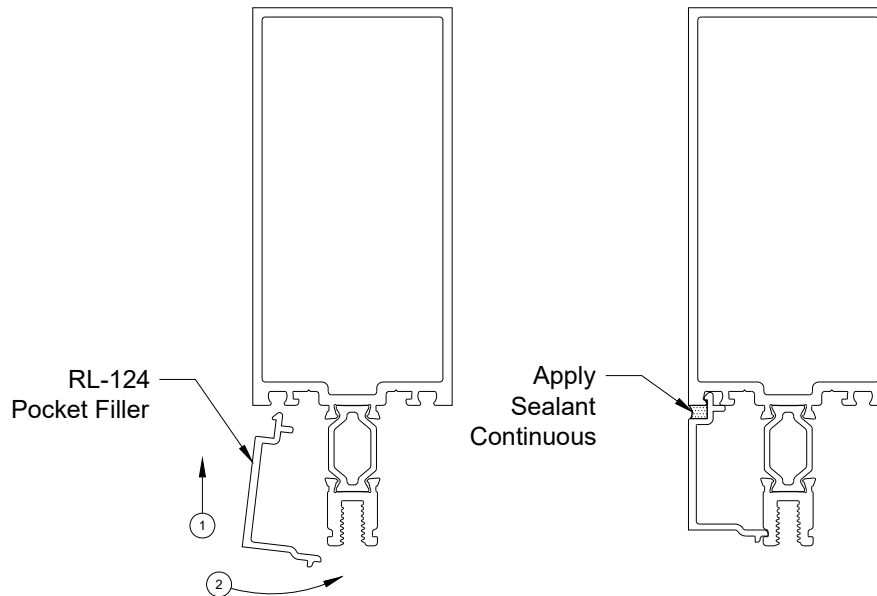

Figure 32: Pocket Filler Installation at Jamb

RELIANCE™ - TC LT Curtain Wall Installation and Glazing Manual

Mullion Cap Installation

- 10.8 Apply silicone sealant to Sill and/or Head end of Vertical and attached Mullion Cap with **FS-320** Fastener(s) as shown in *Figure 33*. Apply additional sealant as required and tool joint between Cap and Mullion.

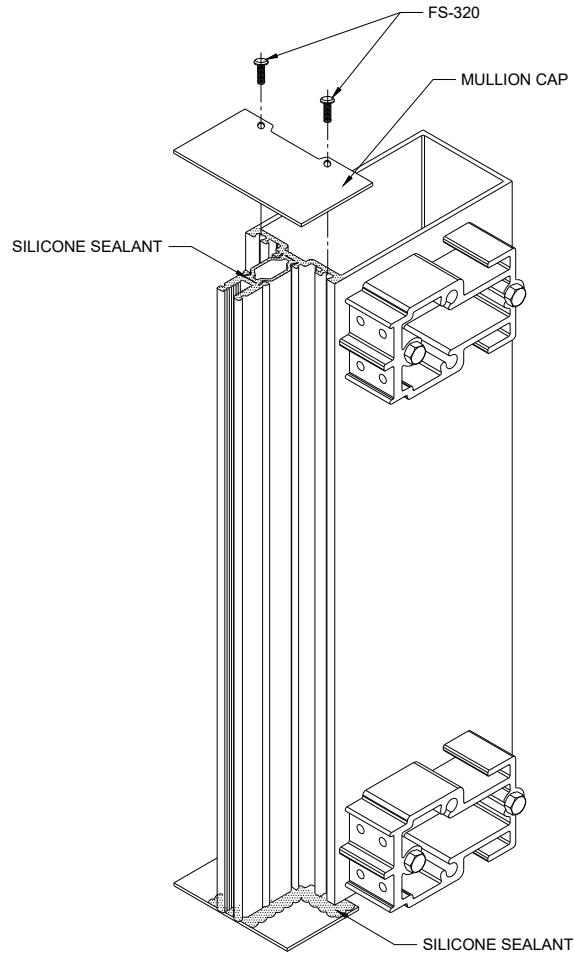

Figure 33: Mullion Cap Installation and Sealing

RELIANCE™ - TC LT Curtain Wall Installation and Glazing Manual

Splice Sleeve Installation

- 10.9 Slide splice sleeve(s) 4-inches into the head end of the lower mullion, temporarily secure in place and drill (2) letter H (0.266) Ø holes as shown in *Figure 34*.
- 10.10 Remove temporarily securement and bolt splice sleeve(s) to mullion using (2) **1/4"-20 x 2-1/2" HH Bolts**, (4) **1/4" Flat Washers**, and (2) **1/4"-20 Hex Nuts**.
- 10.11 Stake the bolts after tightening, ensuring not to overtighten.

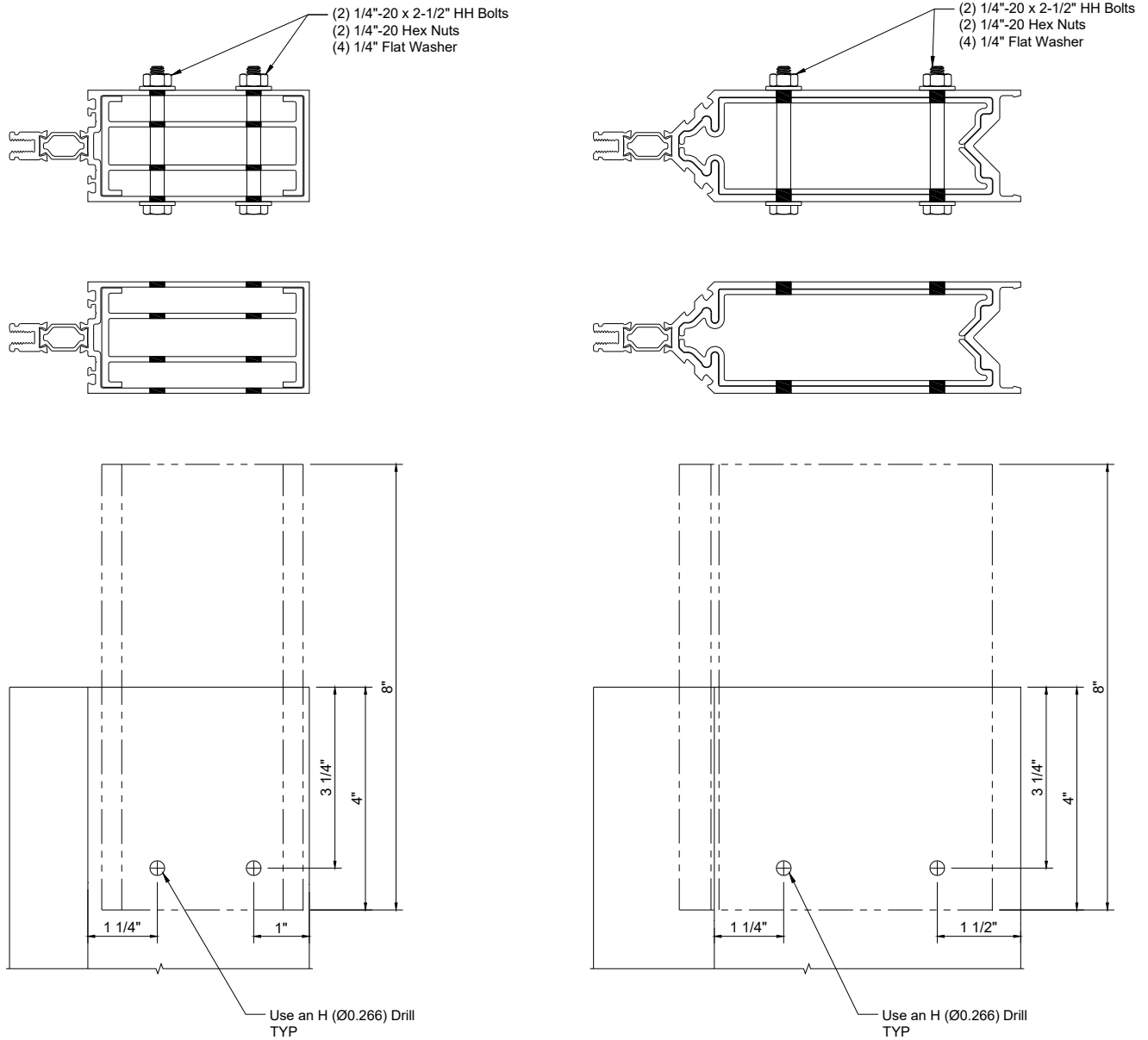

Figure 34: Splice Sleeve Attachment

RELIANCE™ - TC LT Curtain Wall Installation and Glazing Manual

Optional Transition Glazing Adaptor Tongue Installation (SSG to Captured)

- 10.12 When using the **RL-142** SSG to Captured Tongue Adaptor, slide **RL-142** into the SSG Vertical prior to installing Vertical.
- 10.13 After ensuring **RL-142** is in the correct location, drill holes into the SSG Mullion using **RL-142** as a guide using a #23 (0.159)Ø drill.
NOTE: Hole location and spacing is to be determined with Engineer's review.
- 10.14 Attach **RL-142** to SSG Mullion with **FS-201** Fasteners; reference *Figure 35*.

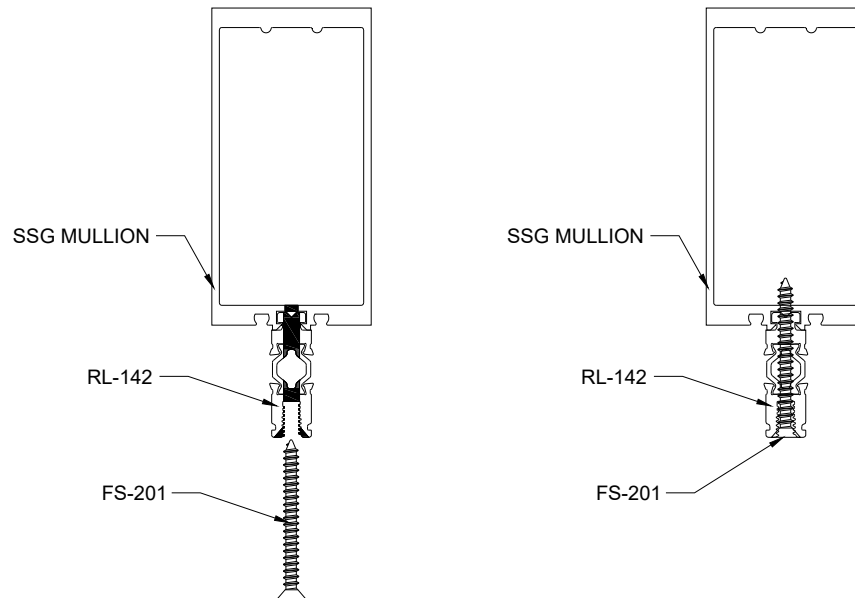

Figure 35: RL-142 to SSG Mullion Attachment

11.0 Single Span Vertical Installation

- 11.1 If using "F" or "T" anchors, slide anchors into top and bottom of Verticals. The anchors are designed to clear the shear block fasteners. See *Figure 36*.
- 11.2 Install Verticals plumb and level. Place shims under Vertical at Sill to evenly distribute dead load from wall. See *Figure 37*.
- 11.3 When using shear block anchors, install pipe sleeve anchor at Head to allow for thermal movement of the Verticals. See *Figure 38*.
NOTE: If roll-over horizontals are used, all vertical mullions can be installed first. If tubular horizontals are used, the wall must be stick erected. Last bay tubular horizontals must be notched. See *Figure 15*. Option: Use roll-over horizontals at last bay to avoid notch.
- 11.4 Check D.L.O. and diagonal dimensions every four bays to ensure correct spacing and frame squareness to prevent dimensional buildup.

RELIANCE™ - TC LT Curtain Wall Installation and Glazing Manual

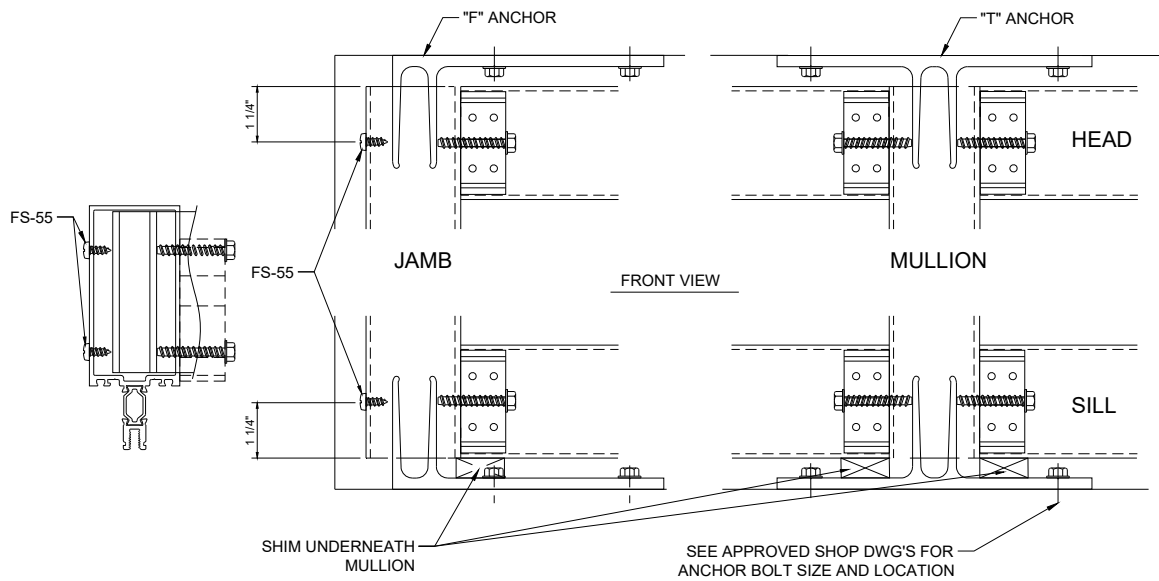

Figure 36: "F" & "T" Anchors

The WW104-02 shear block anchor at head & sill. Maximum load 375 lbs. per anchor, (750 lbs with anchor on both sides of mullion). These capacities are based on proper design for anchor fastener to surrounding conditions.

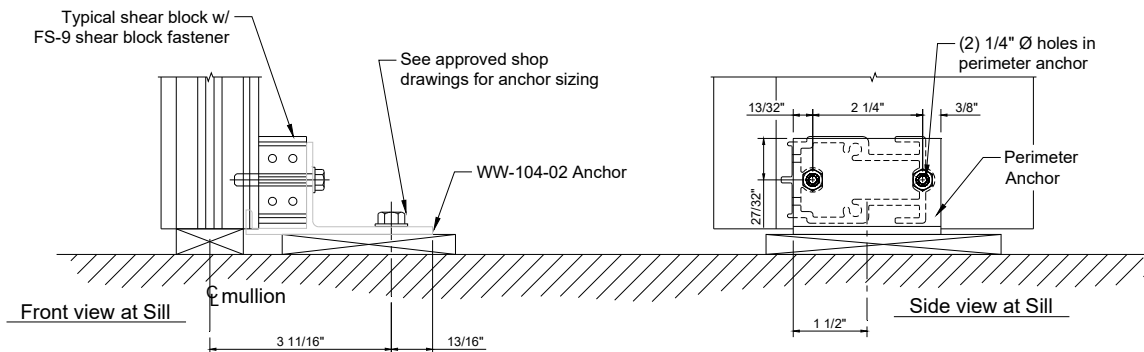

Figure 37: Shear Block Anchorage at Sill (Captured Mullion Shown; SSG Mullion Similar)

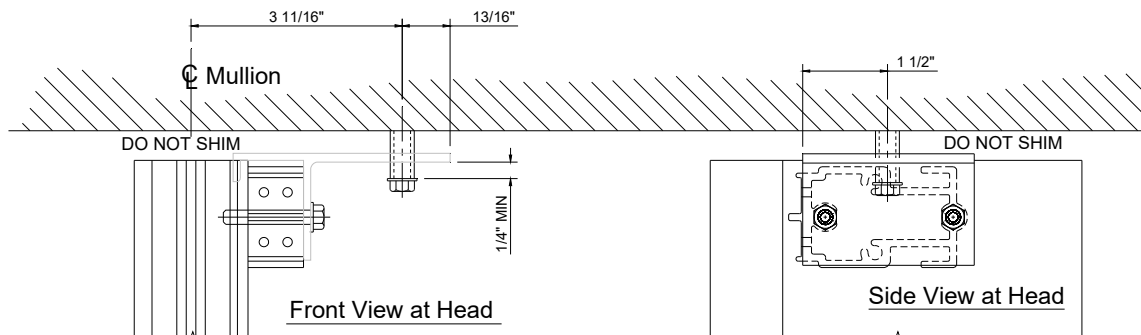

Figure 38: Shear Block Anchorage at Head (Captured Mullion Shown; SSG Mullion Similar)

RELIANCE™ - TC LT Curtain Wall Installation and Glazing Manual

12.0 Twin Span Vertical Installation

- 12.1 When using "F" or "T" anchors, slide anchors into top and bottom of Verticals. The anchors are designed to clear the shear block fasteners. See *Figure 36*.
- 12.2 Install Verticals plumb and level, ensuring proper spacing out from floor slab or beam.
NOTE: If roll-over horizontals are used, all vertical mullions can be installed first. If tubular horizontals are used, the wall must be stick erected. Last bay tubular horizontals must be notched. See *Figure 15*. Option: Use roll-over horizontals at last bay to avoid notch.
- **Shear Block Anchor Method:** Place shims under Vertical and anchor at Sill to evenly distribute dead load from wall. Anchor top and bottom of mullions to structure.
 - **"F" or "T" anchor Method:** Place shims under Vertical (Anchor is set on building condition) and anchor at Sill to evenly distribute dead load from wall. Anchor top and bottom of mullions to structure.
- 12.3 Anchor Mullion to floor slab or beam. See *Figure 39*. Do not over tighten bolt(s). For expansion anchors, back off nut 1/4 turn and stake bolt.
- 12.4 Check D.L.O. every four bays to ensure correct spacing and prevent dimensional buildup.

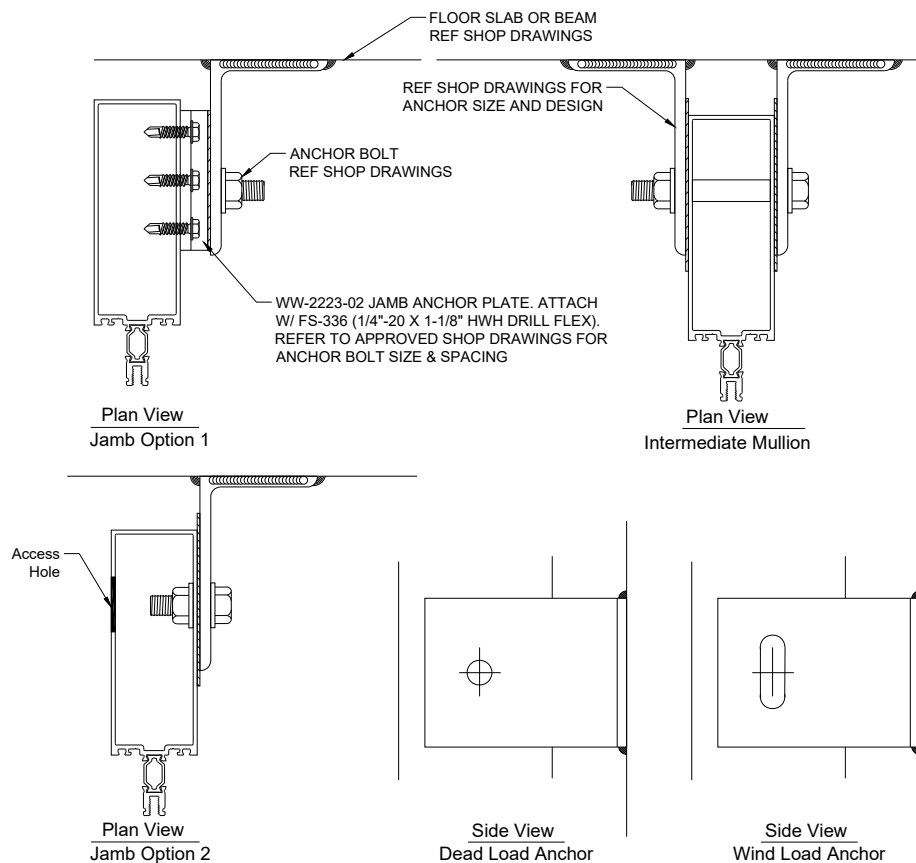

Figure 39: Face of Slab Anchoring Details

RELIANCE™ - TC LT Curtain Wall Installation and Glazing Manual

13.0 Multi-Span Vertical Installation

NOTE: If using expansion horizontals, refer to Section 16.0 (Horizontal Expansion / Vertical Splice Installation & Sealing) on installing/sealing lower part of expansion horizontal prior to installing Verticals.

- 13.1 Install "F" or "T" anchors at the sill condition prior to setting mullions, see Figure 36. Each anchor must be anchored with a minimum of two anchor bolts. See approved shop drawings for bolt size and location.
- 13.2 Install lower Verticals plumb and level, ensuring proper spacing out from floor slab or beam. Place shims under Vertical at Sill to evenly distribute dead load from wall.
NOTE: If roll-over horizontals are used, all Verticals can be installed first. If tubular horizontals are used, the wall must be stick erected. Last bay tubular Horizontals must be notched. Option: Use roll-over Horizontals at last bay to avoid notch.
- 13.3 Anchor the mullion to floor slab or beam. See Figure 39. Do not over tighten bolt(s).
- 13.4 Repeat Steps 13.1 - 13.3 until all lower Verticals are in place.
- 13.5 Check the D.L.O. every four bays to ensure correct spacing and prevent dimensional buildup.
- 13.6 Install the next Vertical above, temporarily shimming between Verticals to maintain proper splice joints (refer to approved shop drawings). See Figure 41 and Figure 40.
- 13.7 Slide "F" or "T" anchors into top of upper-most mullions prior to erecting. The "F" or "T" anchors are designed to clear the shear block fasteners. See Figure 36. Attach "F" or "T" anchor to building condition.
- 13.8 When the wall is set, remove shims between vertical mullions at splices, back off nut 1/4 turn at expansion anchors and stake bolts.

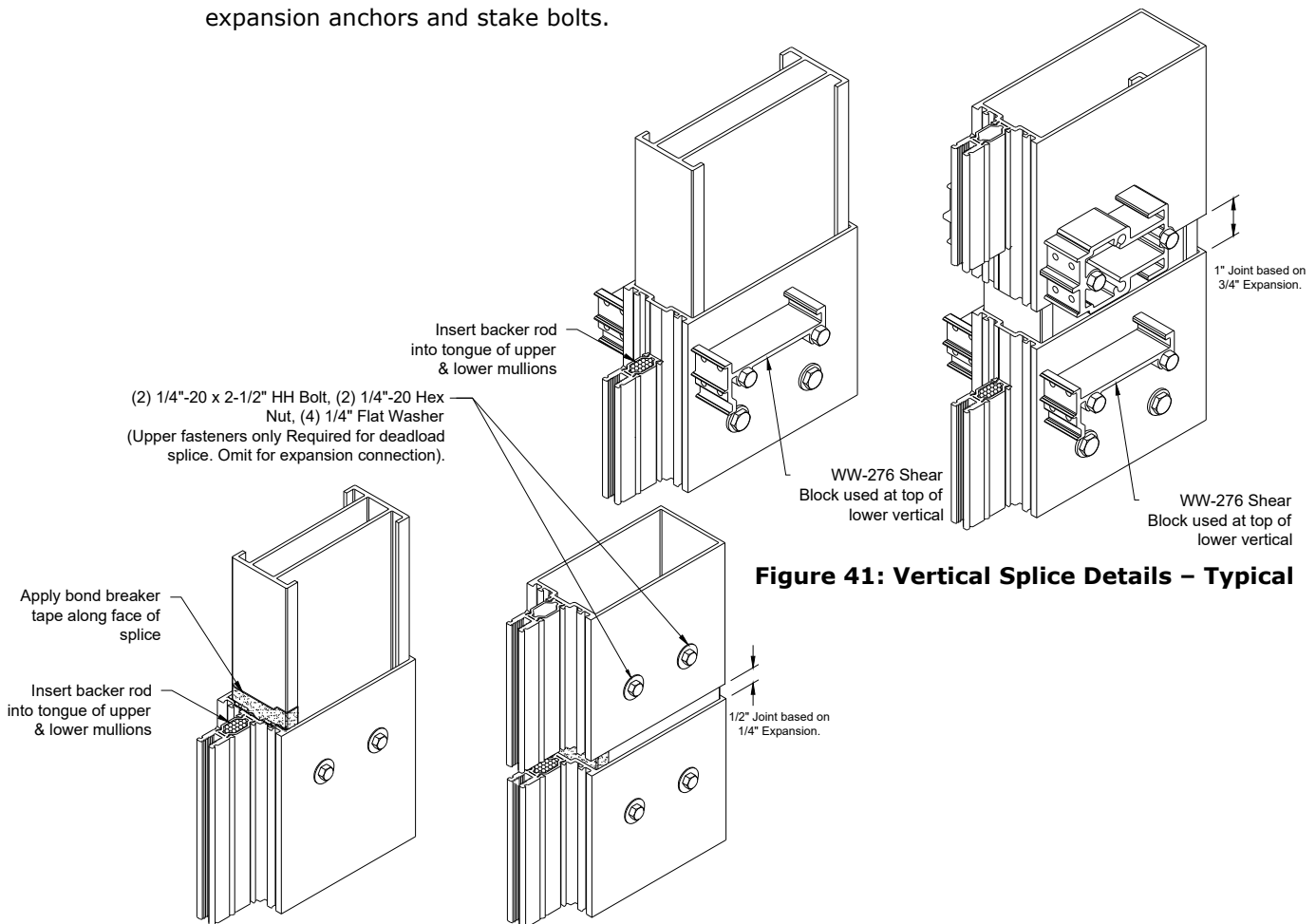

Figure 41: Vertical Splice Details – Typical

Figure 40: Vertical Splice Details – Expansion Horizontal

1-866-OLDCASTLE (653-2278)

OBE.com

Version: 2023-1013

Copyright © 2023 Oldcastle BuildingEnvelope®
All rights reserved.

™ ® Trademarks of Oldcastle BuildingEnvelope and its affiliated companies or respective owners.

RELIANCE™ - TC LT Curtain Wall Installation and Glazing Manual

14.0 Horizontal Member Assembly

Pocket Filler Attachment

- 14.1 Align **RL-122** Pocket Filler along length of Horizontal and attach with **FS-13** Fasteners through pre-drilled holes. See *Figure 42*.
- 14.2 When using **RL-125** Pocket Filler, run a continuous line of sealant the full length of the glazing reglet and Setting Block Chair and align Filler along the length of the Horizontal. Attach Filler with **FS-13** fasteners at 1-1/2" from each end and a maximum spacing of 12" on center. See *Figure 42*.
- 14.3 Run a continuous line of sealant the full length of **RL-122**, as well as cap-sealing over all fastener heads. See *Figure 42*.

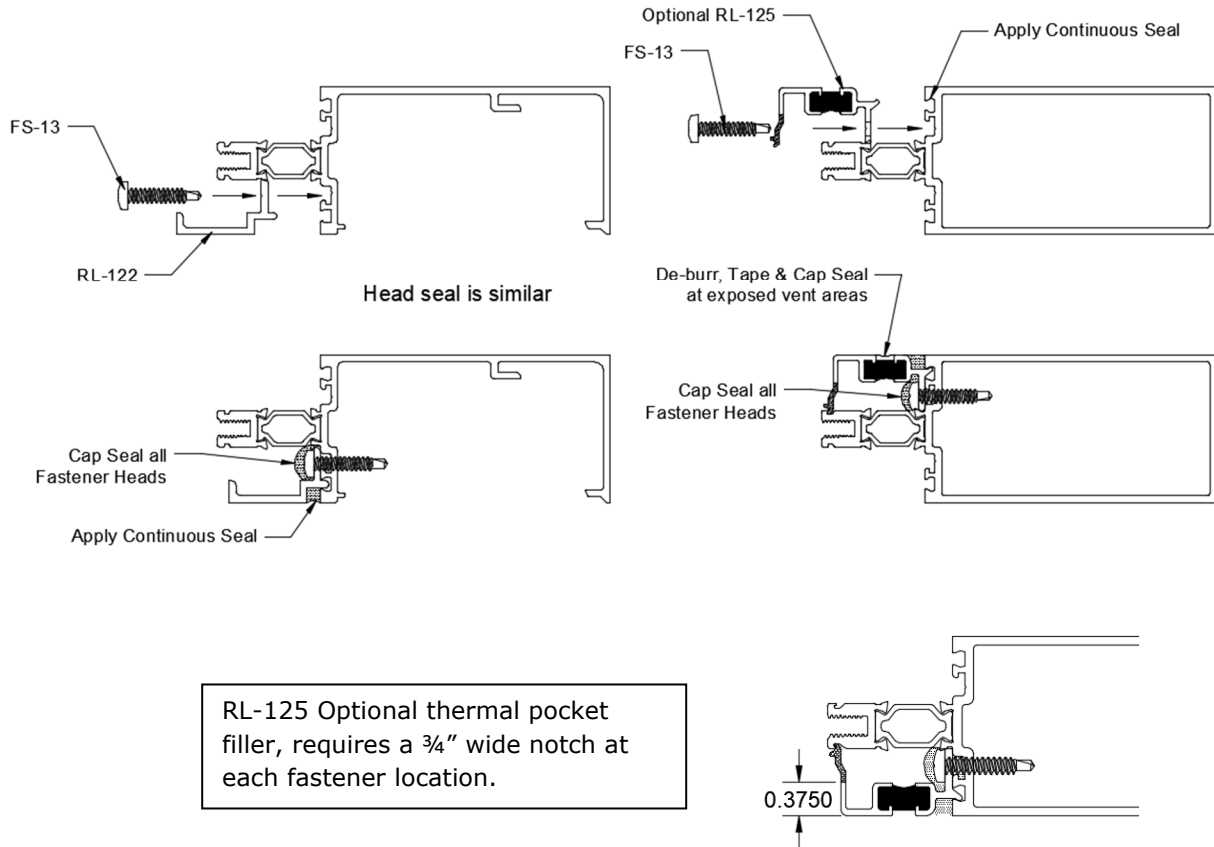

Figure 42: Horizontal Pocket Filler Attachment

RELIANCE™ - TC LT Curtain Wall Installation and Glazing Manual

Expansion Horizontal Gasket Retainer Attachment

- 14.4 Fill gasket reglet and setting block chair groove at lower half of Mullion with sealant.
- 14.5 While sealant is still wet, apply **RL-257** and bed in sealant, per *Figure 43*.
- 14.6 Attached **RL-257** with **FS-19** Fasteners through pre-drilled holes.

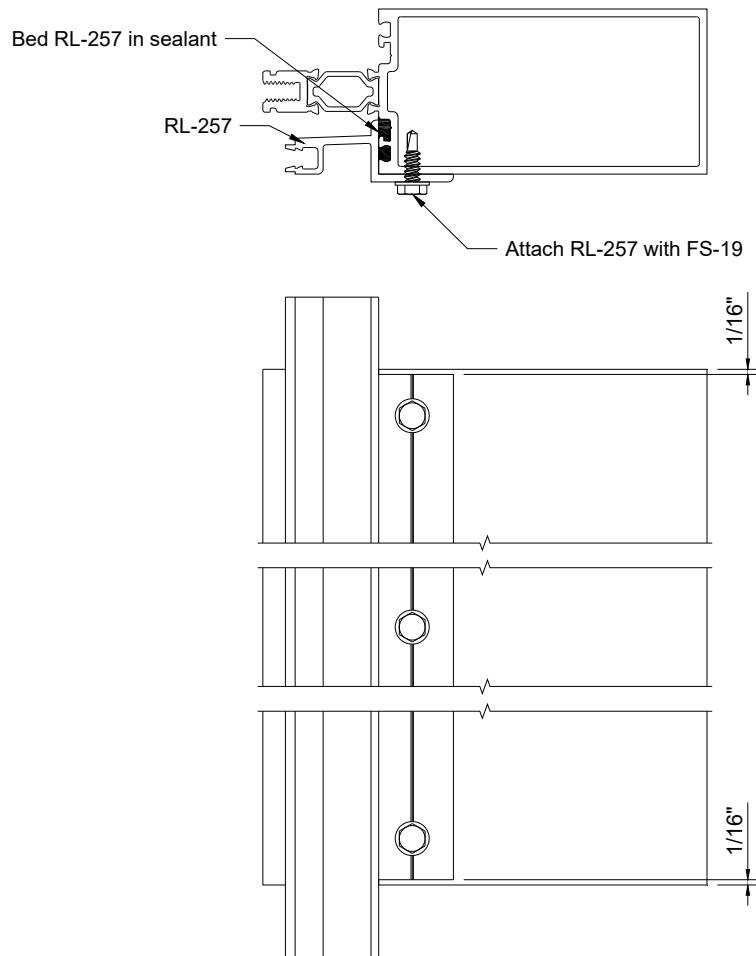

Figure 43: RL-257 Expansion Gasket Receiver Attachment

RELIANCE™ - TC LT Curtain Wall Installation and Glazing Manual

15.0 Horizontal Installation and Sealing

NOTE: Typically completed after installation/erection of all verticals. If roll-over horizontals are used, all vertical mullions can be installed first. If tubular horizontals are used, the wall must be stick erected. Last bay tubular horizontals must be notched. Option: Use roll-over horizontals at last bay to avoid notch.

15.1 Just prior to installing the horizontal member, seal around shear blocks as shown in *Figure 44*.

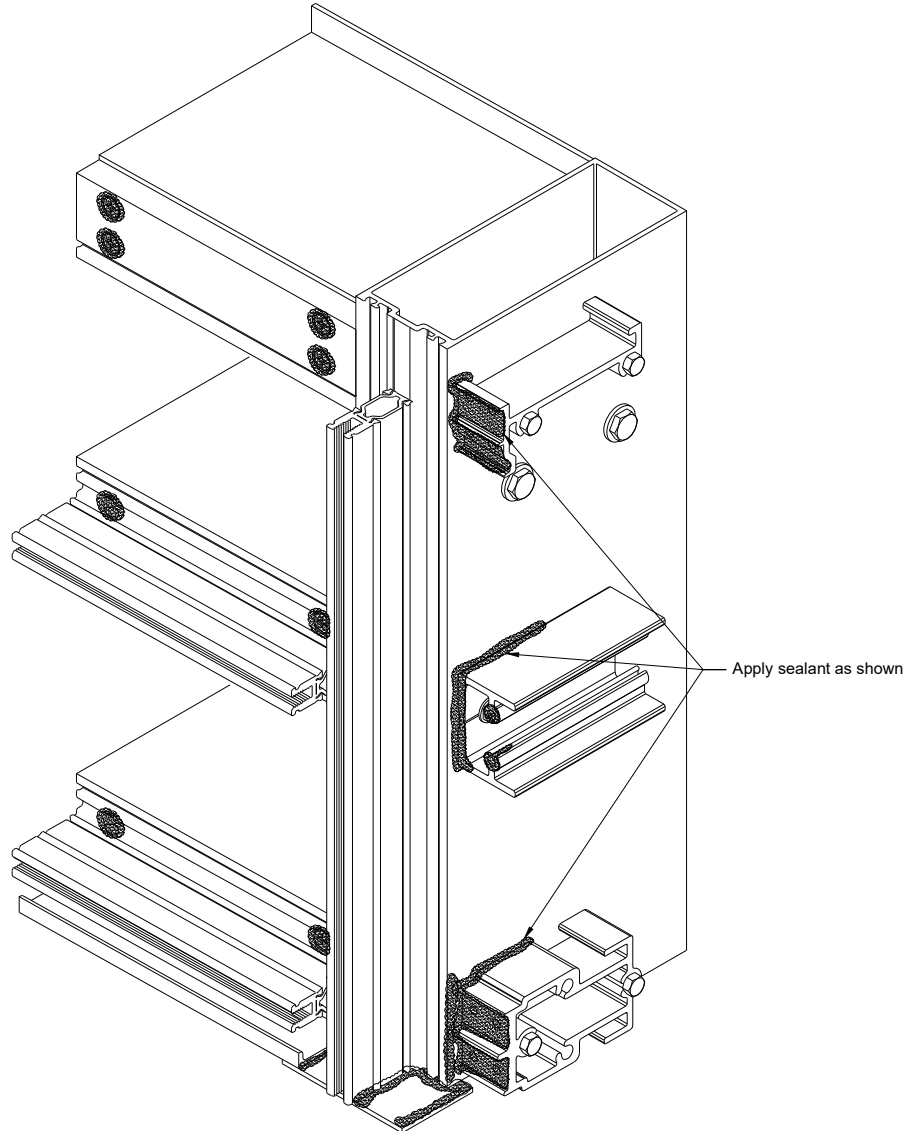

Figure 44: Shear Block Sealing

15.2 Add sealant over the sides of the End Dam. Slide Horizontal in front of the Shear Block and push backward into position, making sure sealant is forced through fastener holes and secure with (2) **FS-7** Fasteners on each end of the member. If sealant is not forced through sealant hole, apply a liberal amount to that hole before installing Fastener. See *Figure 45*. **FS-7** can be cap sealed around the fastener head and in the splines to the left and right of the fastener head.
Note: Tool sealant at Sill where Sill members' perimeter filler meets the End Dam.

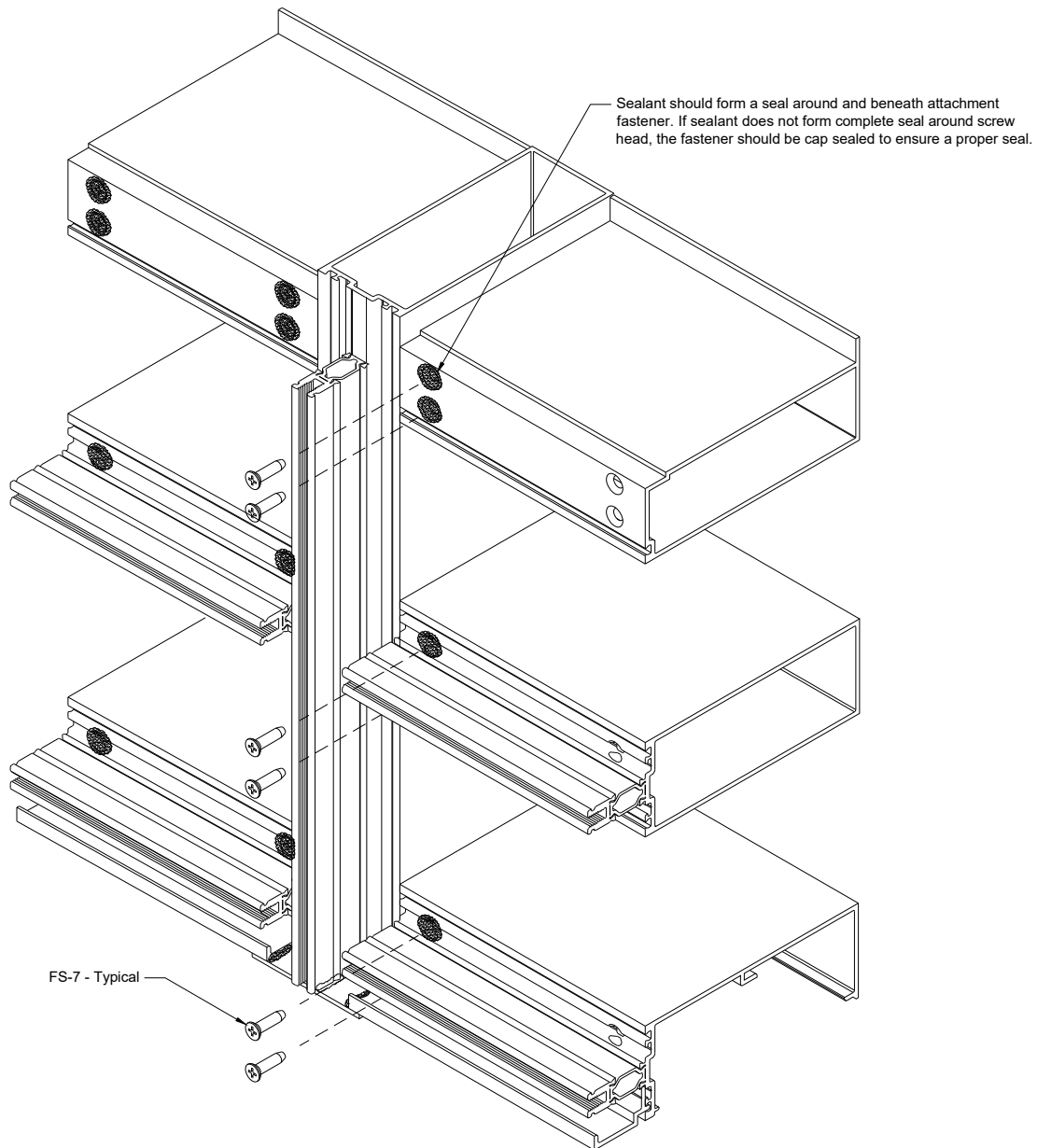

Figure 45: Typical Horizontal Attachment

- 15.3 Tool sealant into the joint between Horizontal and Vertical at the glazing pocket. Avoid a buildup of sealant on the gasket surfaces or in the gasket reglets. Wipe away excess sealant.
TIP: Use a short piece of interior Glazing Gasket to clean out excess sealant in glazing reglets. Also wipe excess sealant away from the horizontal filler snap areas on roll-over horizontals.
- 15.4 If applicable, install cover plates for roll-over horizontals.
- 15.5 Apply sealant to all contact surfaces on Vertical and Horizontal mullions where Zone Plugs will be installed. Apply sealant to horizontal tongue receptor on Zone Plug and install at the end of each Horizontal, Head, and Sill. Tool any excess sealant around front end of Zone Plug where thermal spacer abuts. Tool sealant in the glazing pockets to ensure a watertight fit. See *Figure 46* and *Figure 47*.

RELIANCE™ - TC LT Curtain Wall Installation and Glazing Manual

FIGURE 46
ZONE PLUG INSTALLATION

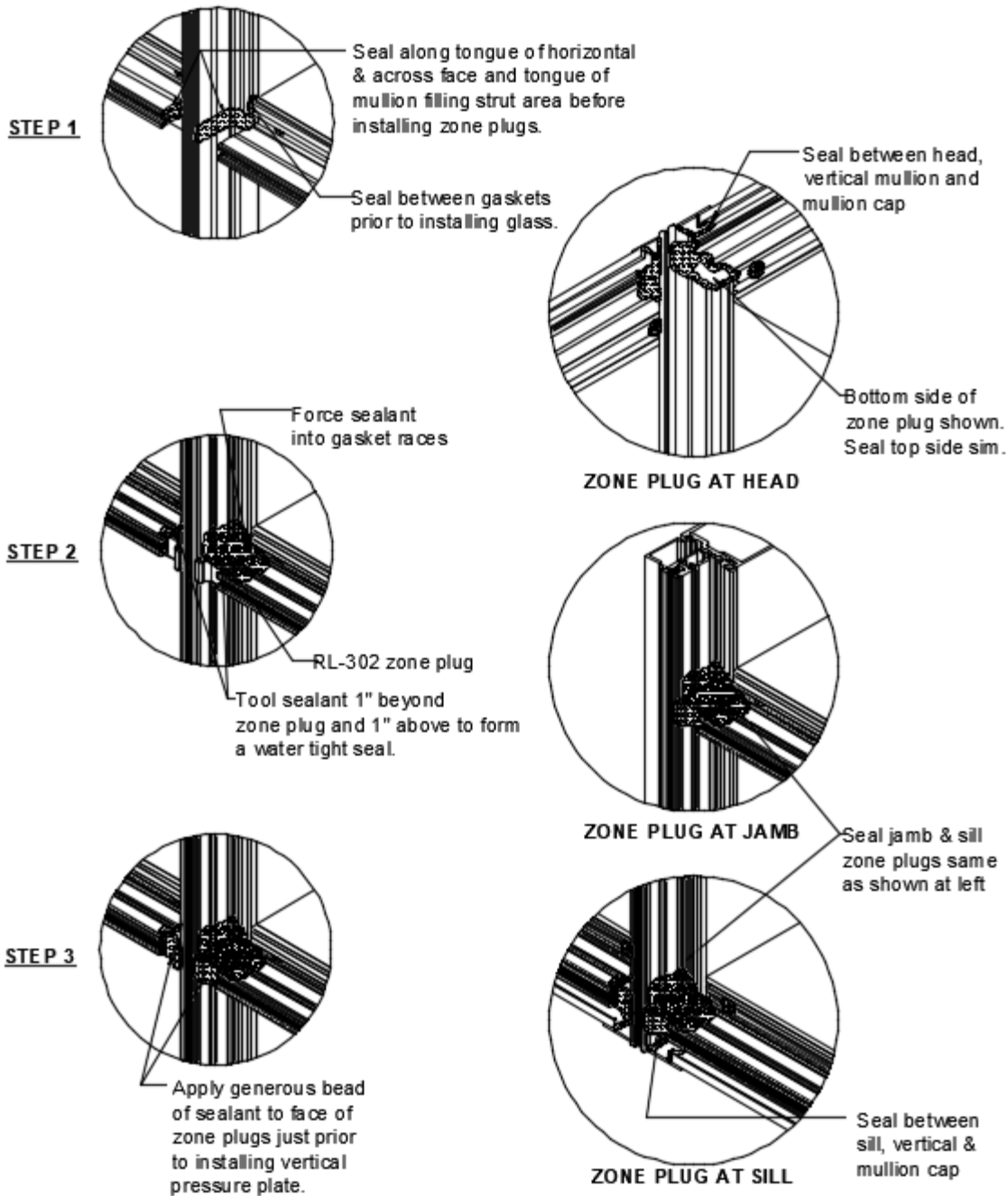

Figure 46: Zone Plug Installation

RELIANCE™ - TC LT Curtain Wall Installation and Glazing Manual

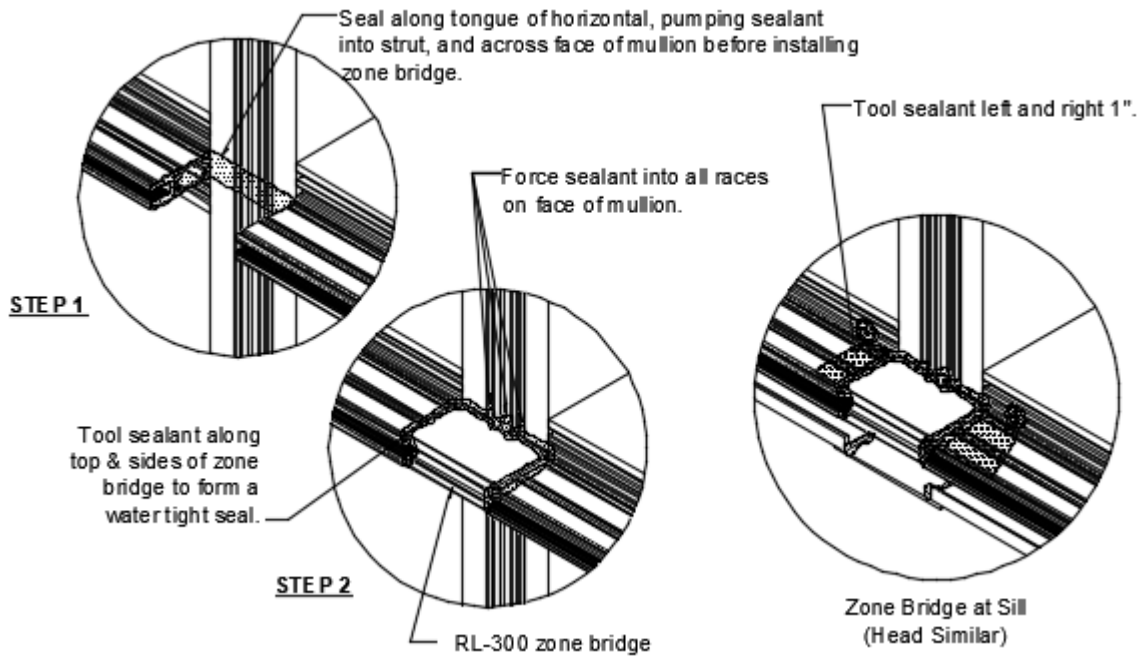

Figure 47: SSG Zone Plug Installation

RELIANCE™ - TC LT Curtain Wall Installation and Glazing Manual

16.0 Horizontal Expansion / Vertical Splice Installation & Sealing

Note: Follow sealant manufacturer's guidelines for proper joint width based on anticipated movement. A minimum 1/2" joint is recommended. Standard splice joints are engineered to accommodate thermal expansion only. They do not allow for movement in floor levels. Refer to approved shop drawings for special circumstances or contact your nearest Oldcastle BuildingEnvelope® facility.

Standard Vertical Splice

- 16.1 Ensure bond breaker tape has been applied to Splice Sleeve, and backer rod has been inserted into the strut cavity of both mullion sections.
- 16.2 Fully seal joint between Mullion across the face, tongue, and a minimum of 1" along the sides of the mullion joint, see *Figure 48*.
- 16.3 Discontinue glazing adapters at splice joints. Install backer rod into cavity and seal between adapters. Marry adapter seal with main mullion seal.

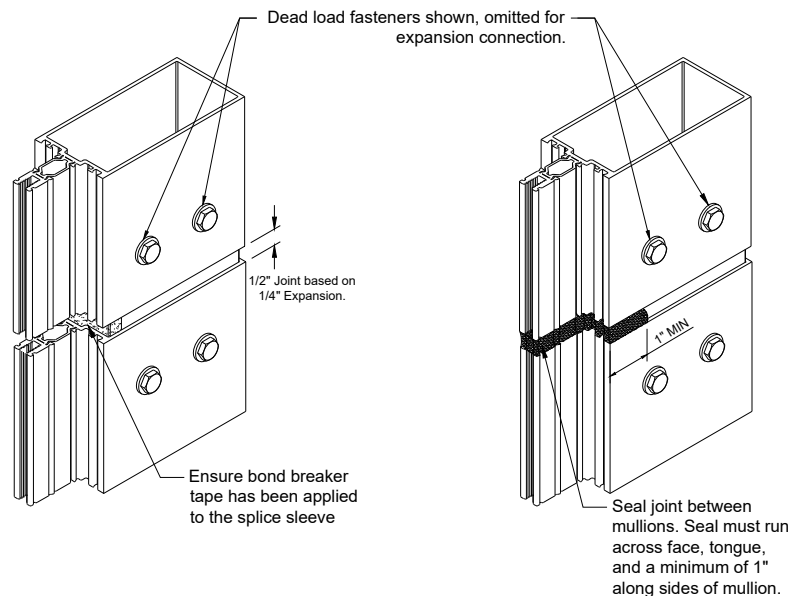

Figure 48: Standard Vertical Splice Joint Sealing

Horizontal Expansion Mullion

- 16.4 Bellows gasket retainers, **RL-257** & **WW-258**, are fabricated to allow a 1/4" joint at intermediate mullions and full width of jamb mullion.
- 16.5 After installing lower Horizontal at expansion horizontal, install **WW-258** lower Gasket Retainer to face of Horizontal. Bed Gasket Retainer in a continuous bead of sealant and cap-seal all fasteners. A 1/4" joint will be located at Mullion centerlines. Attach with **FS-19** Fasteners at 9" on center.
- 16.6 Install **HP-1004** Baffles, held in place using **SPW-295** Baffle Retainer. Apply a small amount of sealant to back edge of **SPW-295** to hold in place during shipment. Seal ends of Horizontal to Verticals as shown in *Figure 49*.
- 16.7 After lower framing is installed, install 4" long strips of Silicone Sheet to **WW-258** Retainers at center line of each Vertical. Bed sheet in sealant and tool to form a splice connection, as shown in *Figure 52*.

- Note:** All sealant work must be complete on lower framing prior to installing upper framing.
- 16.8 Install upper Horizontal at expansion Horizontal, per Section 15.0 (*Horizontal Installation and Sealing*), using **FS-7** Fasteners at top side of Shear Block on each side (The fastener location at the bottom side of Shear Block is behind the **RL-257**). See *Figure 50*.

RELIANCE™ - TC LT Curtain Wall Installation and Glazing Manual

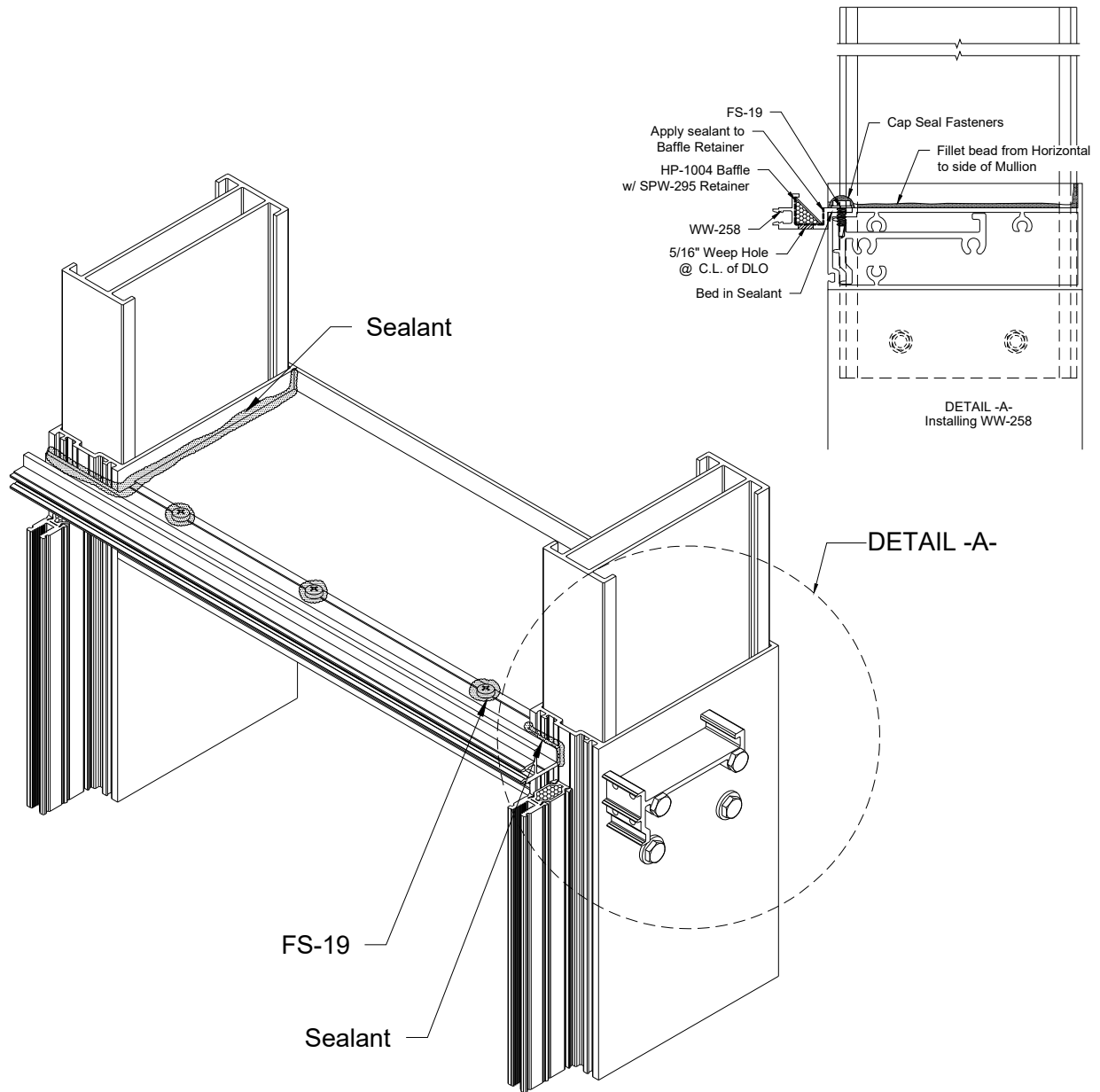

Figure 49: Horizontal Assembly

RELIANCE™ - TC LT Curtain Wall Installation and Glazing Manual

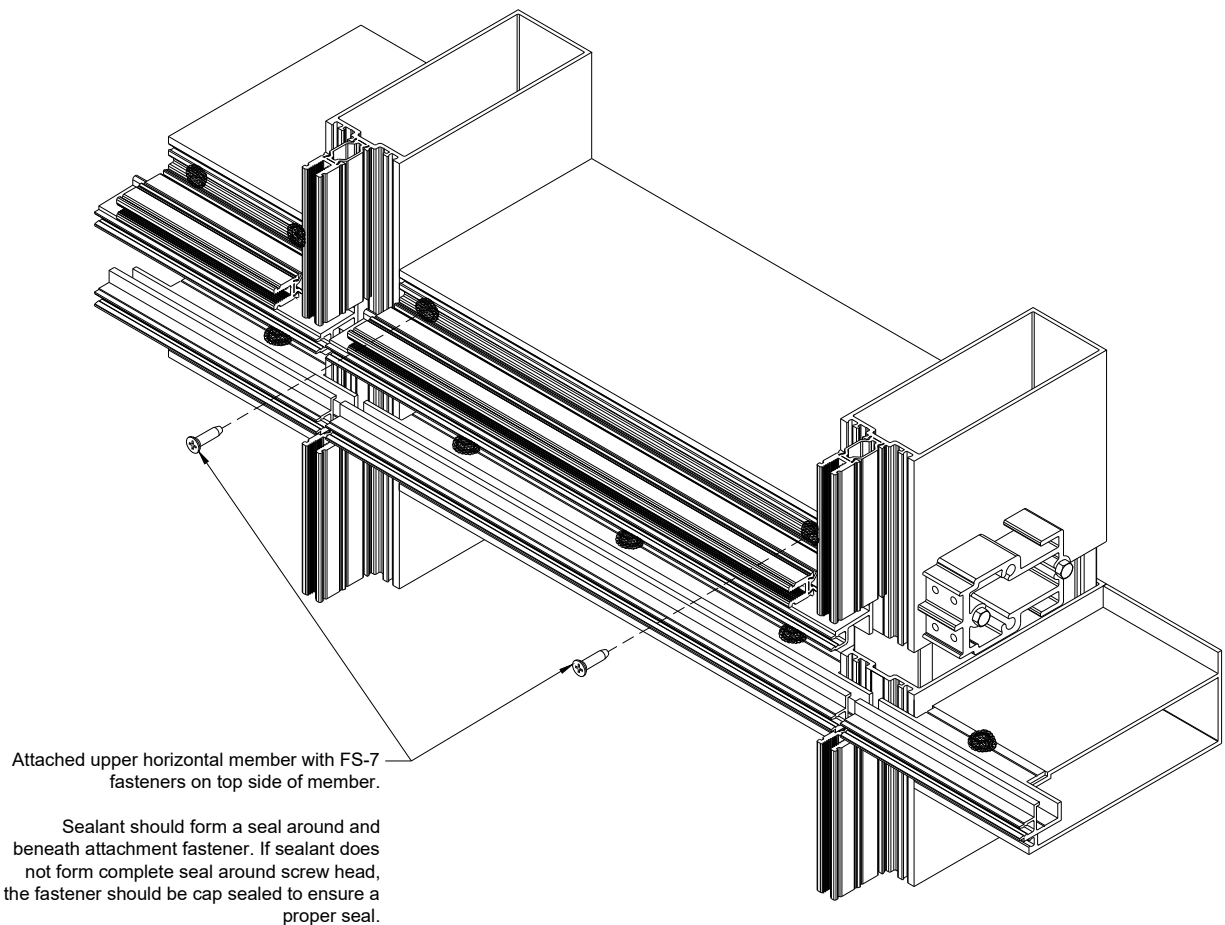

Figure 50: Upper Expansion Horizontal Assembly and Sealing

- 16.9 Drill #23 (0.159") Ø x 3/4" deep holes at both end of the upper Horizontal per *Figure 51*. Countersink to 0.403 Ø x 82° and attach with **FS-7** Fasteners at each end.
- 16.10 After framing is installed, install 4" long strips of Silicone Sheet to **RL-257** Retainers at center line of each Vertical. Bed Sheet in sealant and tool to form a splice connection. Install Silicone Sheet and sealant at **WW-258** in lower unit prior to installing unit above. See *Figure 52*.
- 16.11 Fill gasket race of **RL-257** with continuous bead of sealant and insert **GP-144** Gasket into races for **RL-257** and **WW-258**. Leave ends of Gasket loose at jambs or corners and set once molded jamb or corner gaskets are installed. See *Figure 52*.
- 16.12 Install **GP-144-01** Jamb Sleeve (corner gasket similar) by sealing the **RL-257** gasket race, sealing end flap and installing onto mullion and mull splice. Once in place, run bead of sealant across splice section of jamb gasket. Install **GP-144** Gasket over jamb splice and then run exterior bead of sealant over splice area to create watertight seal. See *Figure 52*.
- 16.13 When using the optional **RL-583** Horizontal a **WW-259** interior Snap on Cover will be required. Cover must be notched to clear jamb mullions and intermediate mullions. If Cover is run across intermediate Vertical, then a 2-1/2" notch will also be fabricated at these locations. Where Cover needs to be spliced at intermediate mullions, the notch will be 1-1/4" long and Cover will be cut at Mullion centerline minus 1/16" to form a 1/8" joint. See *Figure 53* for butt joint.
Note: **GP-32007** Gaskets are to be pre-installed into the **WW-259** Trim prior to installation. Cut to trim length, slide into gasket races and stake at both ends to secure.

RELIANCE™ - TC LT Curtain Wall Installation and Glazing Manual

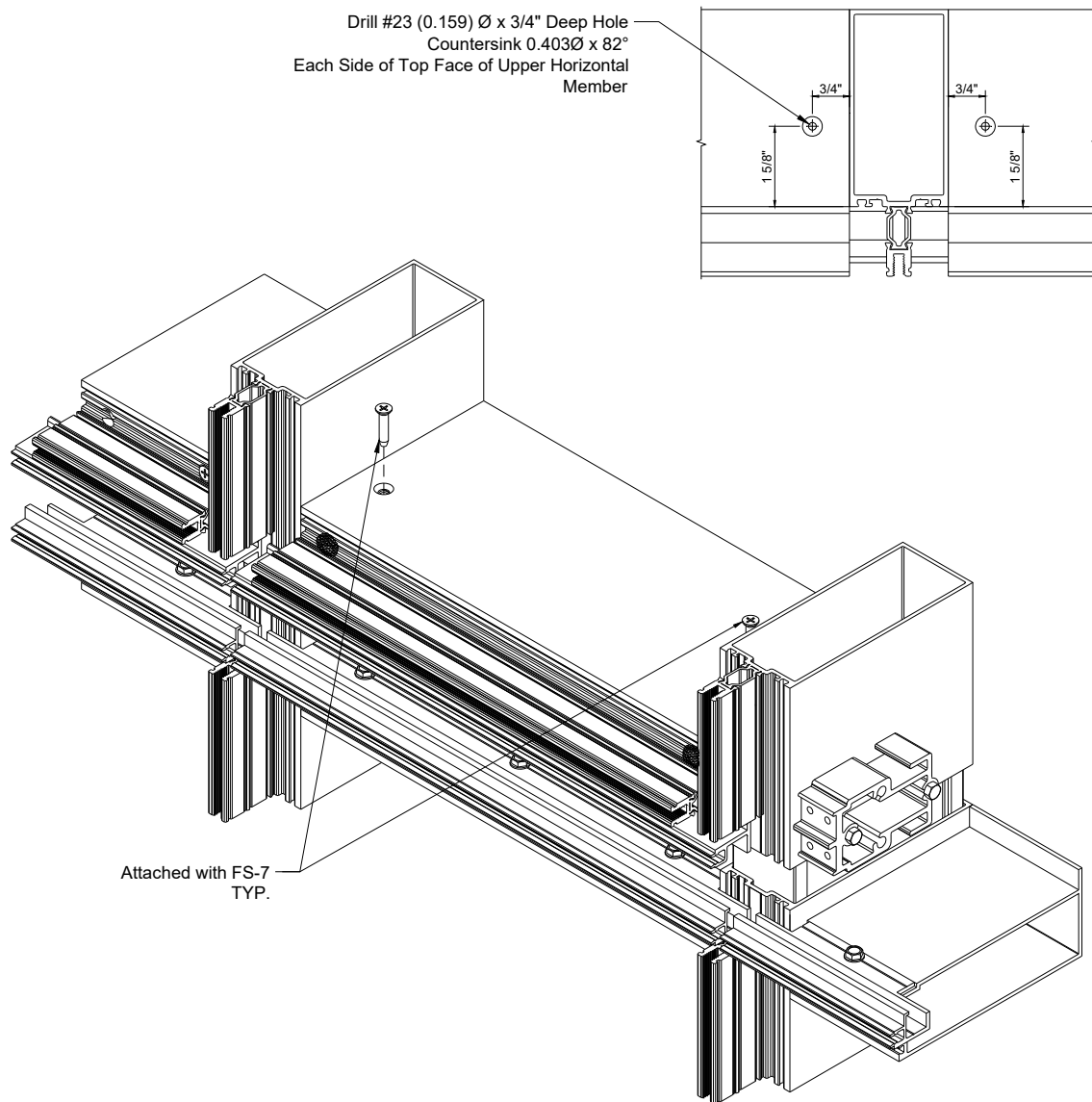

Figure 51: Upper Expansion Horizontal Shear Block Fastening

RELIANCE™ - TC LT Curtain Wall Installation and Glazing Manual

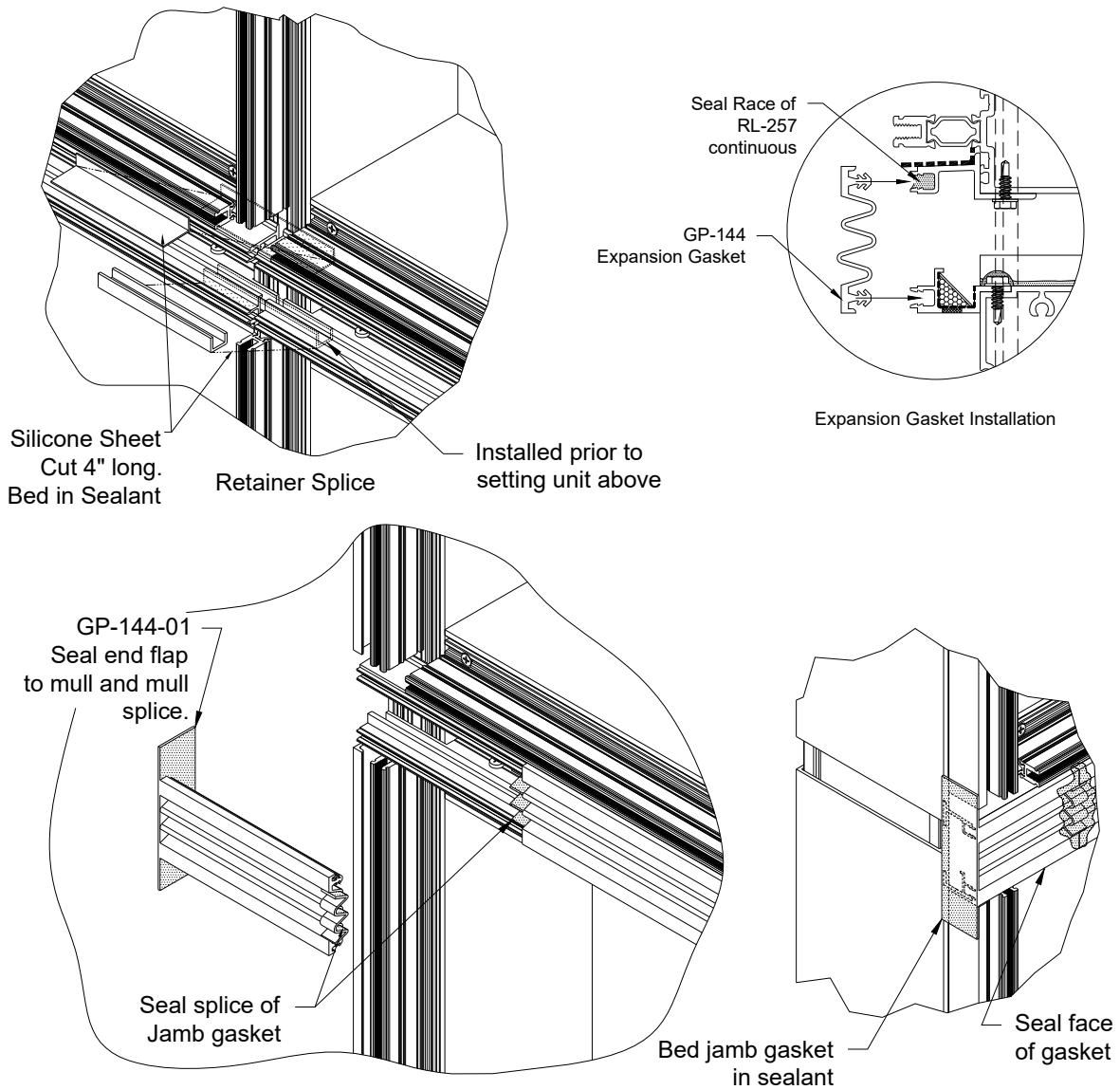

Figure 52: Expansion Horizontal Sealing

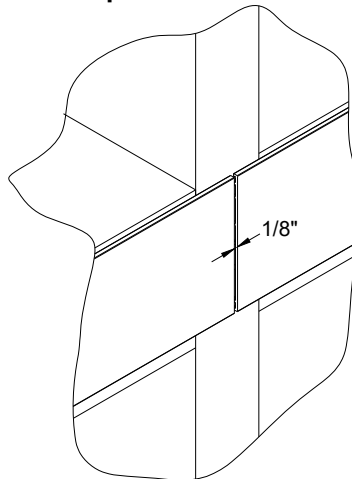

Figure 53: WW-259 Intermediate Mullion Splice Joint

RELIANCE™ - TC LT Curtain Wall Installation and Glazing Manual

17.0 Perimeter Sealing

When all framing members are installed, apply the perimeter seal. See *Figure 54*. An interior perimeter seal is not required for system performance but can be installed for cosmetic purposes. Perimeter sealing must be completed prior to glazing.

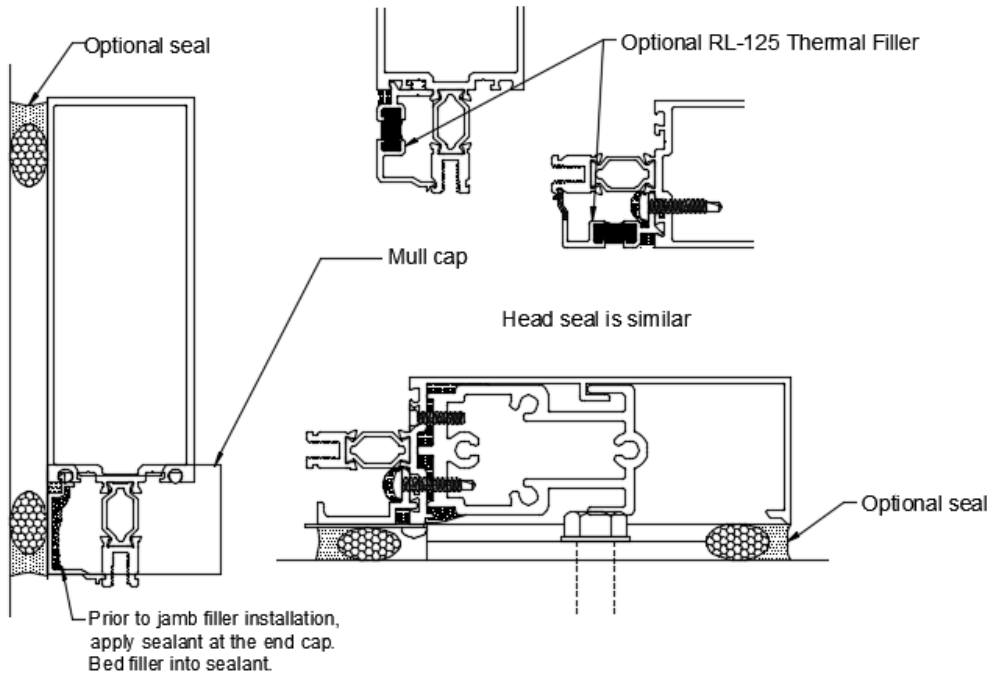

Figure 54: Perimeter Seal

RELIANCE™ - TC LT Curtain Wall Installation and Glazing Manual

GLAZING

18.0 Optional Glazing Adapter Installation

18.1 See *Figure 55* for glazing options.

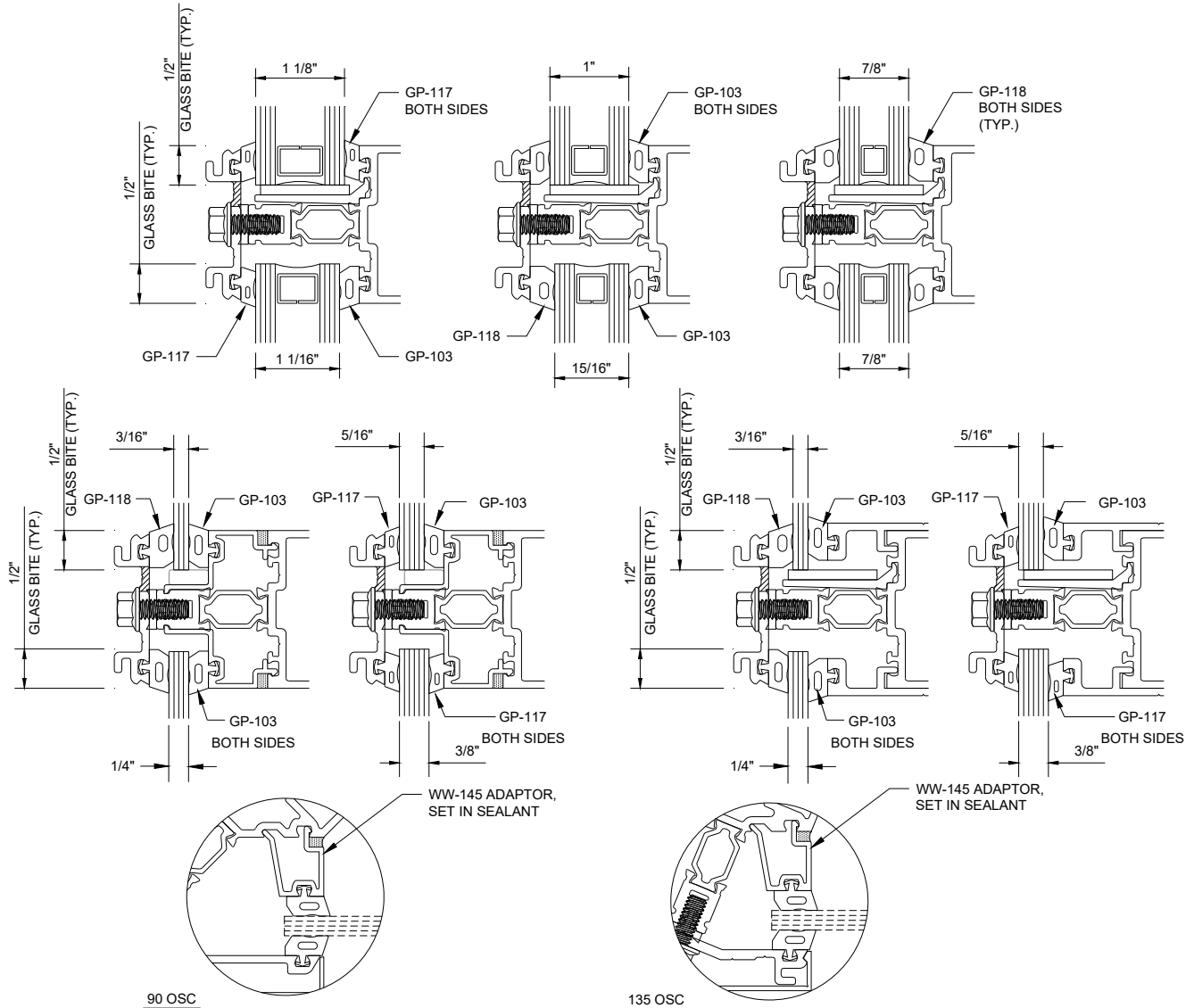

1-1/2" GLASS POCKET
 RL-162-03 PRESSURE PLATE w/ GP-191 ISOLATOR (SHOWN)
 RL-163-03 PRESSURE PLATE w/ GP-191 ISOLATOR

Figure 55: Glazing Options

- 18.2 Install vertical adapters first, leaving an equal overlap into each pocket. For captured Verticals and all Horizontals, insert the hook side into the glazing reglet, then insert leg into reveal on Mullion. See *Figure 56*. Refer to Section 16.0 if Vertical is spliced within a spandrel lite. Glazing adapters must be installed after Mullion splice is sealed.
- 18.3 For SSG mullions, install locator leg into one of the glazing reglets. Locate, match drill, and seal penetrations, then secure to Mullion with **FS-318** Fastener 3" from the ends and 12" on center. See *Figure 56*.

RELIANCE™ - TC LT Curtain Wall Installation and Glazing Manual

18.4 Install horizontal adapters maintaining an equal gap at each end. Once all adapters have been installed in the opening, seal all joints between Vertical and Horizontal adapters. Run a bead of sealant in the groove formed between the adapter and Mullion. This seal must be continuous around opening and must marry with the seal at Horizontal to Vertical adapter joints. See *Figure 58*.

Note: For horizontal adapters that are adjacent to SSG mullions, a small notch must be made to the tongue engagement hook in order to clear the SSG mullion bridge. See *Figure 57*.

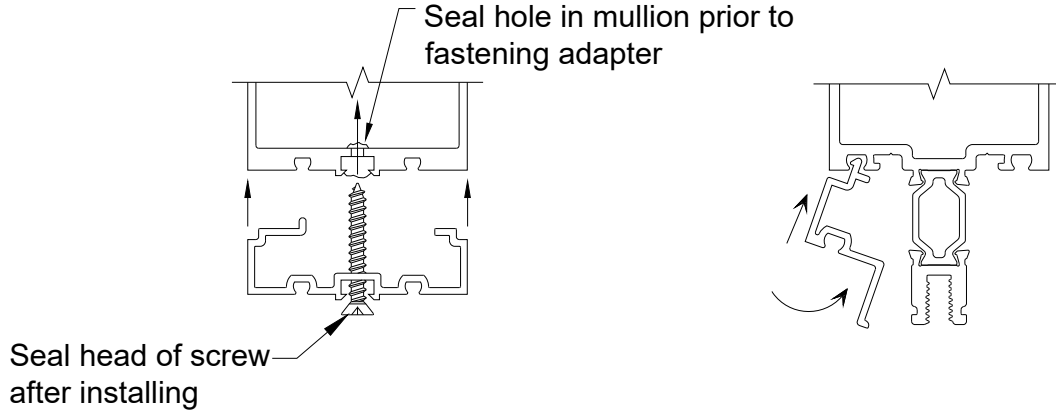

Figure 56: Installing Glazing Adapters

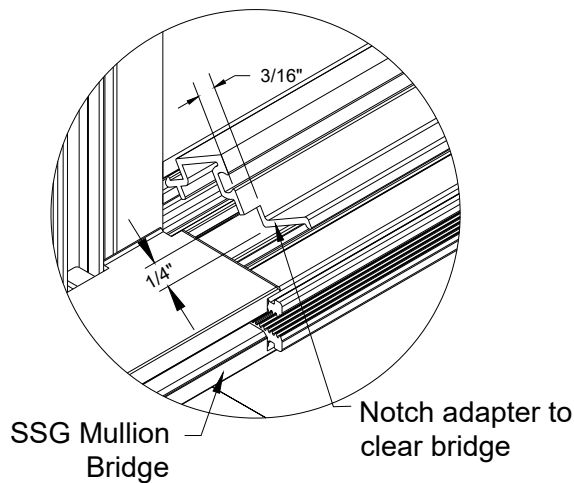

Figure 57: Notching Adapter for SSG Mullion Bridge

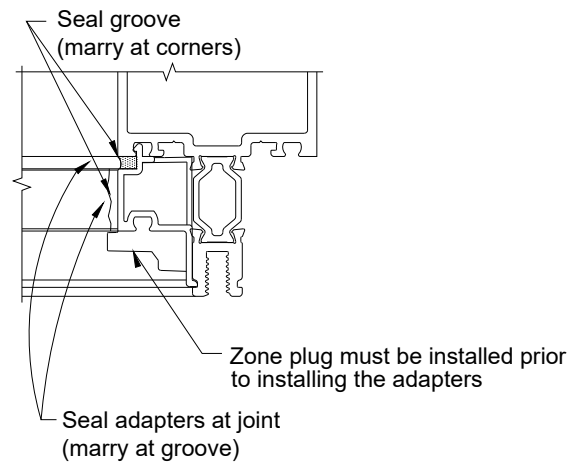

Figure 58: Sealing Glazing Adapters (Vertical Shown; Horizontal Similar)

RELIANCE™ - TC LT Curtain Wall Installation and Glazing Manual

19.0 Preparation of Frame Opening for Glass

Prepare the frame opening by removing all dirt and debris from the glazing pockets, pressure plates and gasket reglets.

SETTING BLOCKS

- Set glass on two setting blocks, part number noted in the shop drawings. The preferred location is at the 1/4 points.

DEFLECTION

- If the 1/4 point location causes excessive deflection of the intermediate horizontal, move the setting blocks equally towards the corners of the lite as far as the 1/8 points. The outer end of the block **CANNOT** be closer than 6" to the corner of the glass.
- The intermediate horizontal must not exceed 1/8" and a door header is limited to 1/16". Check deadload charts for proper setting block locations.

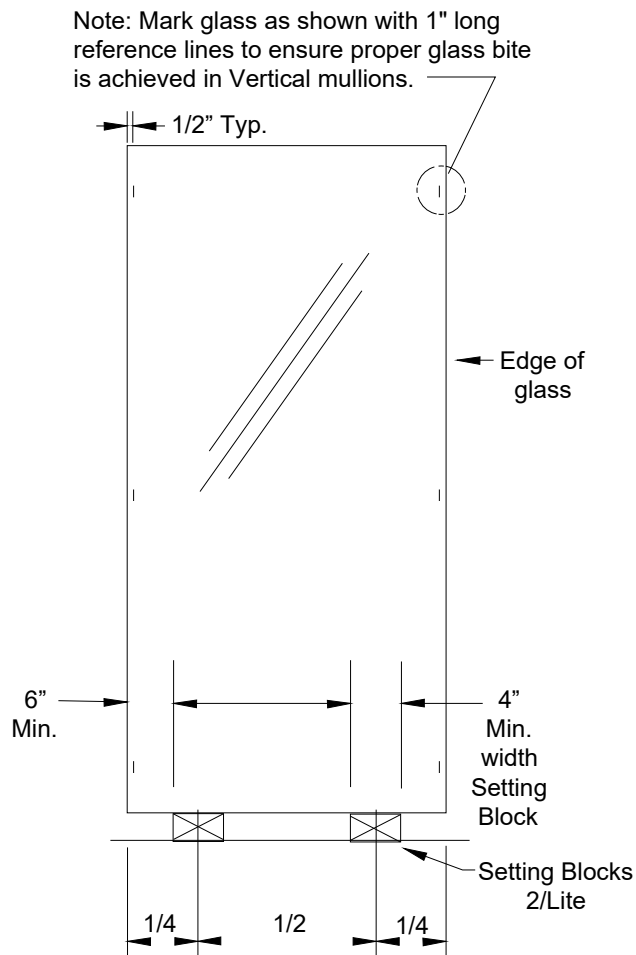

Figure 59: Glass Marking and Setting Blocks

RELIANCE™ - TC LT Curtain Wall Installation and Glazing Manual

20.0 Interior Gasket and Setting Blocks

- 20.1 Install Face Gaskets into all Pressure Plates.
- 20.2 Install silicone Spacer Gaskets into the SSG Mullions. Crowd all Gaskets into members to avoid gaps caused by relaxation of Gasket material.
- 20.3 Install thermal spacer into groove on face of Mullion tongues. Run through at typical Vertical splice joints. Cut short 1/8" from each end of the Mullion. See *Figure 60*.
- 20.4 Install 2" of **GP-142** Isolator Gasket at **RL-300** Zone Bridges per *Figure 61*, as required.

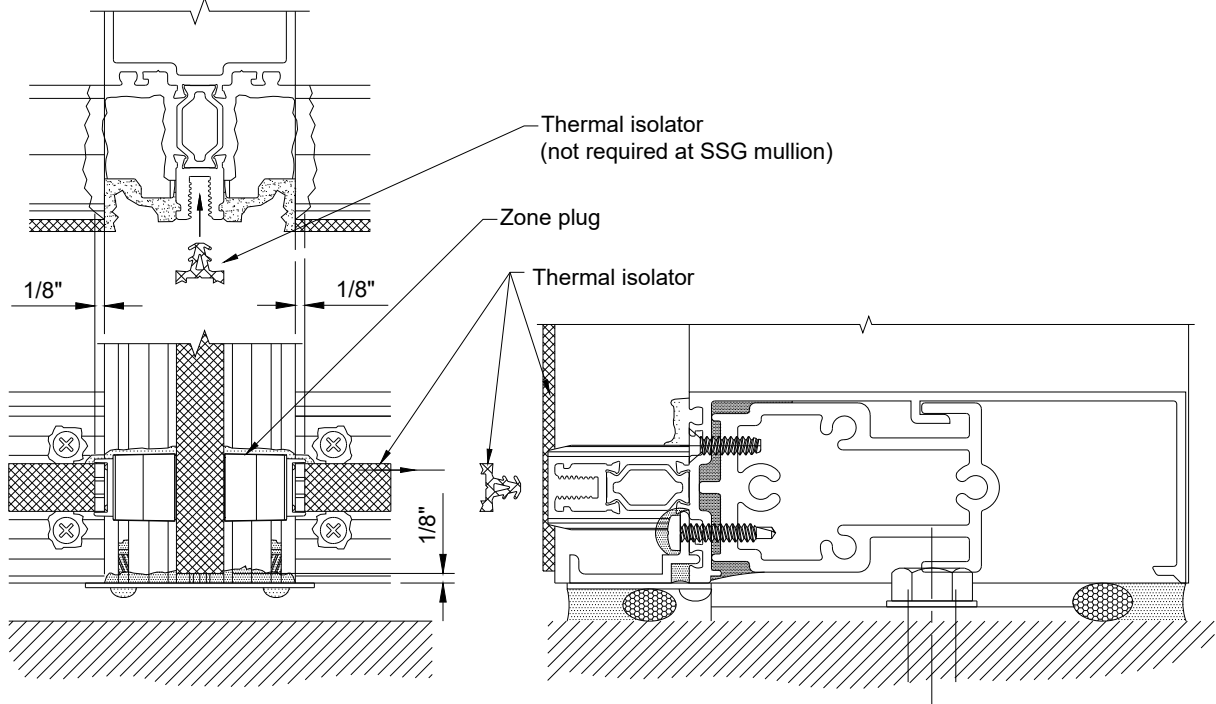

Figure 60: Thermal Isolator Installation

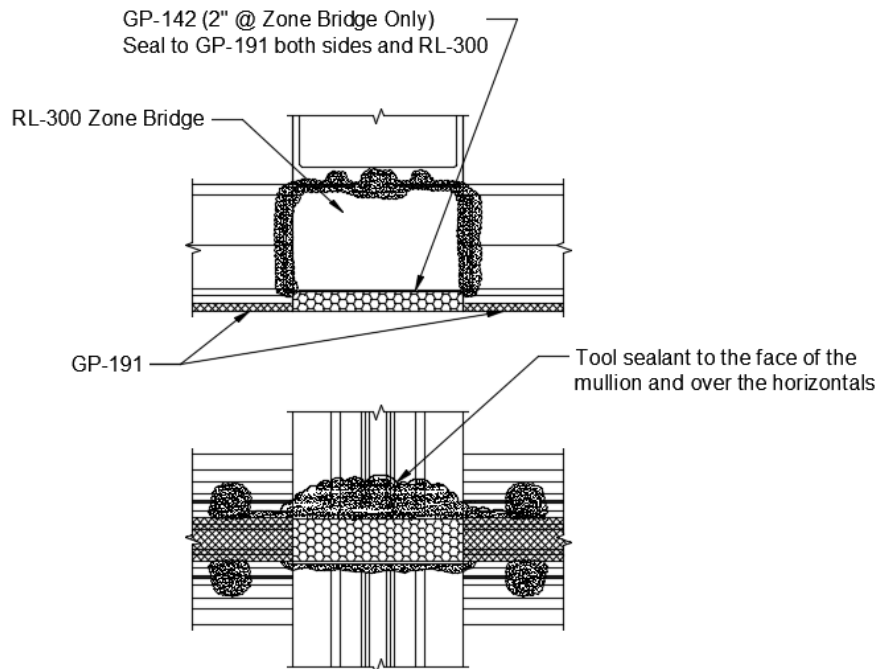

Figure 61: Isolator Gasket at Zone Bridge

1-866-OLDCASTLE (653-2278)

OBE.com

Version: 2023-1013

Copyright © 2023 Oldcastle BuildingEnvelope®
All rights reserved.

™ ® Trademarks of Oldcastle BuildingEnvelope and its affiliated companies or respective owners.

RELIANCE™ - TC LT Curtain Wall Installation and Glazing Manual

20.5 Install Interior Glazing Gasket.

Note: To avoid silicone curing before glass is set in place and contamination from job-site debris, glazing prep must be done as each opening is glazed. Do not pre-seal Gaskets in the entire frame; seal only Gaskets in the opening for which you are ready to set glass.

- Install Interior Gaskets into back member (vertical gaskets first). If Mullion is spliced, run Gasket through the splice joint, setting in fresh silicone at the joint. Trim the gasket dart as required to form an air-tight seal. (Glazing Gaskets at Verticals run through; horizontal gaskets butt into the vertical gaskets.
- Crowd Gaskets into corners, cutting horizontal Gaskets at a slight angle to conform to the bevel on vertical Gaskets.
- Pulling the horizontal Gasket back at the ends, seal joint at Gasket corners **JUST PRIOR TO GLAZING THE OPENING**. Release the Gasket back to its original position, making sure Sealant fills entire joint.

Note: Sealant is not required at the horizontal Gasket abutting an SSG Mullion. This gap will be sealed during application of structural silicone.

- Tool corner joints after glass is set and Temporary Glazing Retainers are in place.

20.6 Position **RL-127-01** Setting Block Chairs and **GP-192** Setting Blocks at correct location (two per lite). Refer to *Section 19.0* for Setting Block locations. Lubricating the top of Setting Blocks with glass cleaner or soapy water will help ensure proper setting of glass.

Note: Consult glass manufacturer for correct Setting Block location and length for glass sizes more than 40 sq./ft.

RELIANCE™ - TC LT Curtain Wall Installation and Glazing Manual

21.0 Setting Glass

21.1 Set glass in opening. Ensure that correct glass bite is maintained on all sides.

CAUTION: Be certain that glass is placed firmly against Interior Gasket to ensure a proper seal and to avoid binding of the glass on the Setting Block.

- Captured Mullion Glass Bite = 1/2"
- SSG Mullion Glass Bite = 3/4"
- Reference shop drawings for custom conditions

21.2 Temporarily hold glass in the opening with **WW-162-01** Temporary Glazing Retainers and **FS-236** Fasteners. Use **SPW-PP-3** Retainer for SSG verticals. Torque the **FS-236** Fastener to **40-50 in-lbs.**

! SAFETY NOTE: Temporary retainers are not intended to meet safety glazing fall out requirements!

- **WW-162-01** Temporary Glazing Retainers must be applied at each glass edge 3" from the corner (minimum of 8 per lite). Glass edges greater than 4' in length but less than 8' require an additional Retainer at the glass mid-span.
- Retainers are intended for short term use only. Additional Retainers may be required to withstand full design wind load pressures.
- Full length Pressure Plates must be installed if severe weather or high wind loads are anticipated. See *Figure 62* and *Figure 63*.

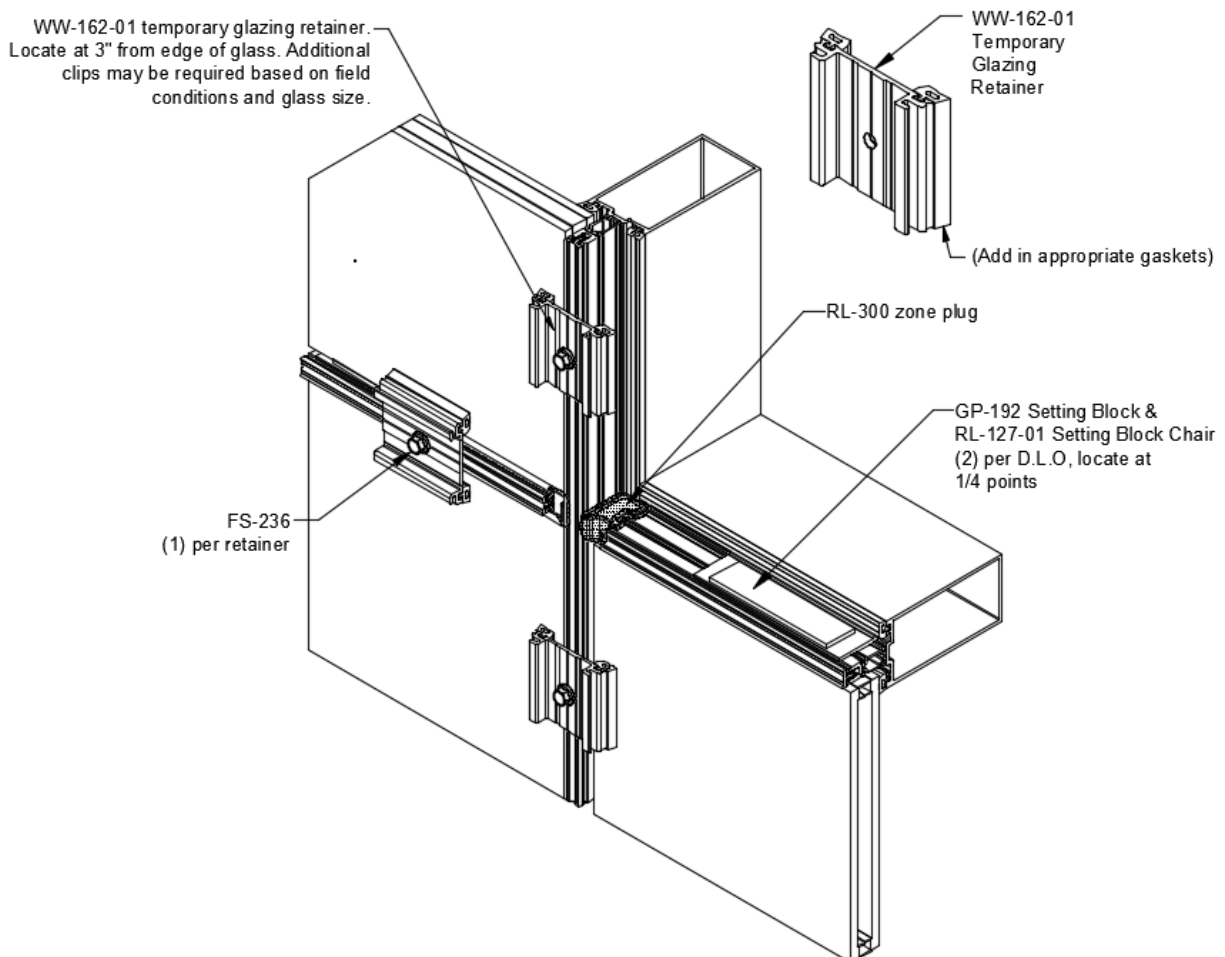

Figure 62: Glazing Instructions

1-866-OLDCASTLE (653-2278)

OBE.com

Version: 2023-1013

Copyright © 2023 Oldcastle BuildingEnvelope®
All rights reserved.

™ ® Trademarks of Oldcastle BuildingEnvelope and its affiliated companies or respective owners.

RELIANCE™ - TC LT Curtain Wall Installation and Glazing Manual

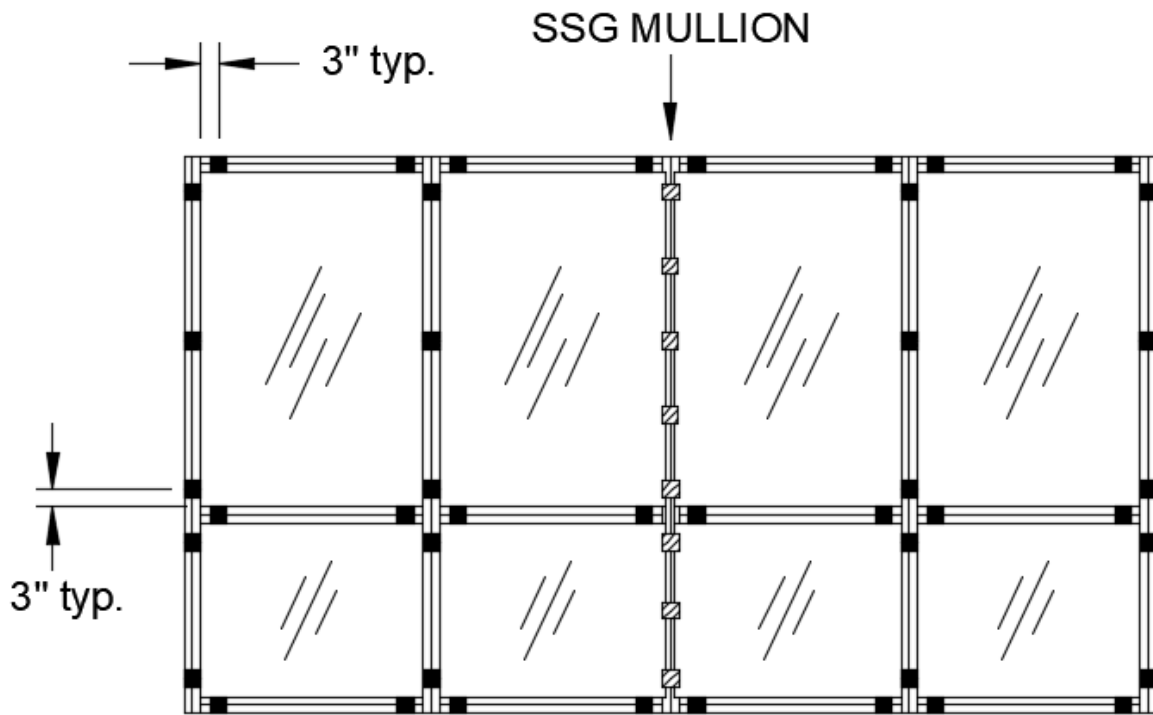

Figure 63: Location of Temporary Glazing Retainers (Typ.)

RELIANCE™ - TC LT Curtain Wall Installation and Glazing Manual

22.0 SSG Application and Sealing

22.1 Apply Structural Silicone per manufacturer's directions. Marry the Structural Silicone to the Interior Glazing Gaskets at the head and sill of the opening. Tool and clean excess Silicone from framing and glass. See *Figure 64*.

22.2 After Structural Silicone has fully cured per manufacturer's direction, remove **SPW-PP-3** Temporary Retainers, and insert backer rod between glass lites. Apply weather seal between glass lites full height of glazing. Tool and clean excess Sealant from glass lites. See *Figure 64*.

Note: Glazing similar on head end of *Expansion Horizontal*.

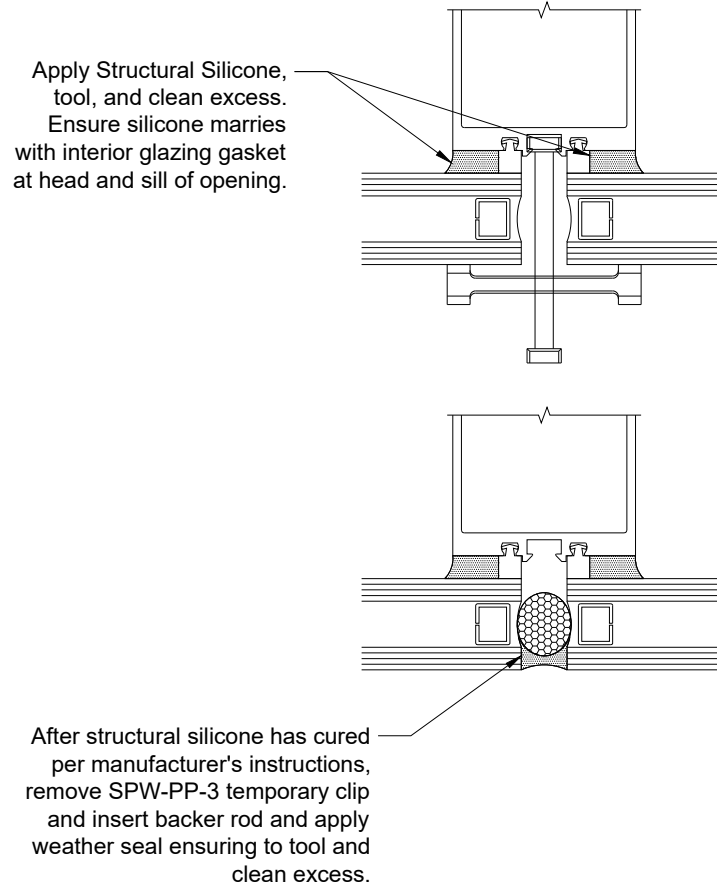

Figure 64: SSG Application and Sealing

RELIANCE™ - TC LT Curtain Wall Installation and Glazing Manual

23.0 Pressure Plate and Face Cap Installation

- 23.1 Install Glazing Gaskets into all Pressure Plates.
- 23.2 If required, install **GP-114** Side Blocks with silicone at centerline of each lite of glass, along vertical edges, or per approved shop drawings. For framing that will be subjected to seismic events, consult glass manufacturer for preferred location.
- NOTE:** Side Blocks are not required at SSG mullions.
- 23.3 Repeat steps in Section 20.0, Section 21.0, Section 23.1 and Section 23.2 until all glass is set, working row by row up the elevation.
- 23.4 At typical vertical splice, insert backer rod between glass and mullion tongue, see Figure 65.

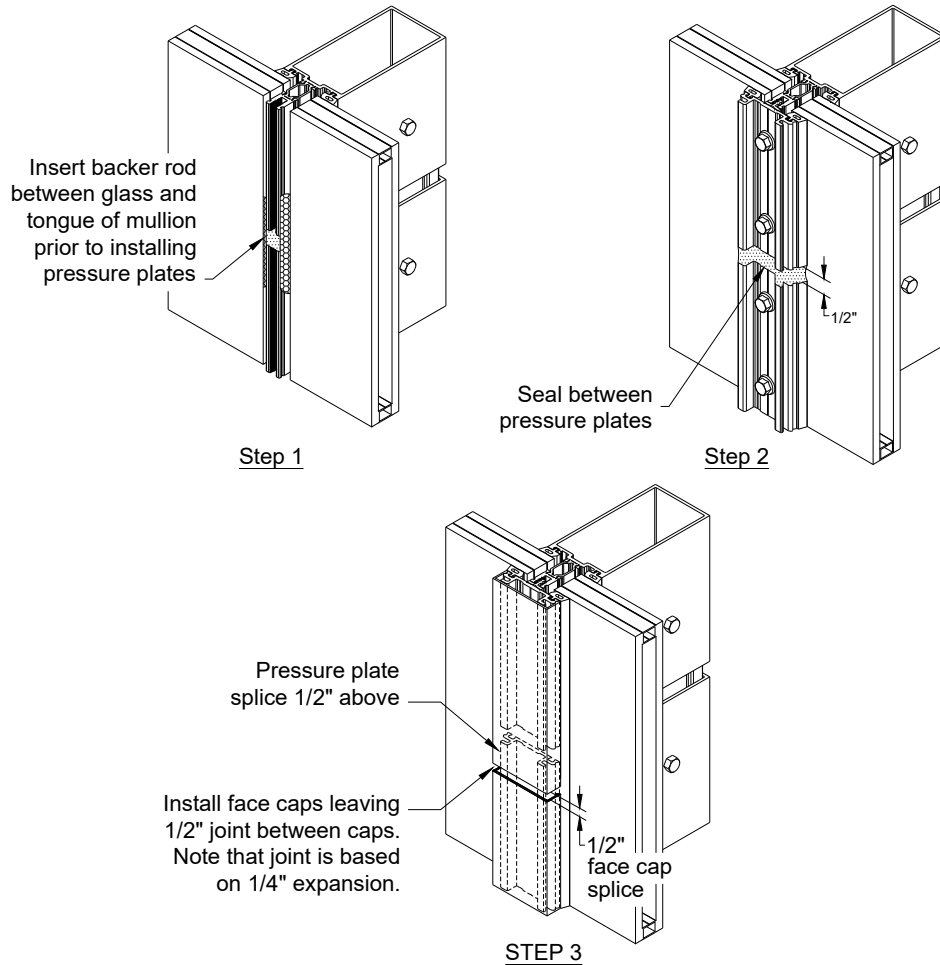

Figure 65: Typical Splice Sealing at Glazing

- 23.5 Prior to installing vertical Pressure Plates, apply sealant to the face of each horizontal Zone Plug, captured Verticals only. See Figure 66. Vertical Pressure Plates and Face Caps must be installed before the horizontal Pressure Plates are applied.

Note: **FS-236** Fasteners (at Aluminum) or **FS-284** Fasteners (at Polyamide) for Pressure Plates must be located 1-1/2" from horizontal/vertical Mullion intersections in order to maintain proper compression on the glass. Drill 17/64" holes in Pressure Plates as required.

DO NOT USE HOLES LESS THAN 1-1/2" FROM THE ENDS.

RELIANCE™ - TC LT Curtain Wall Installation and Glazing Manual

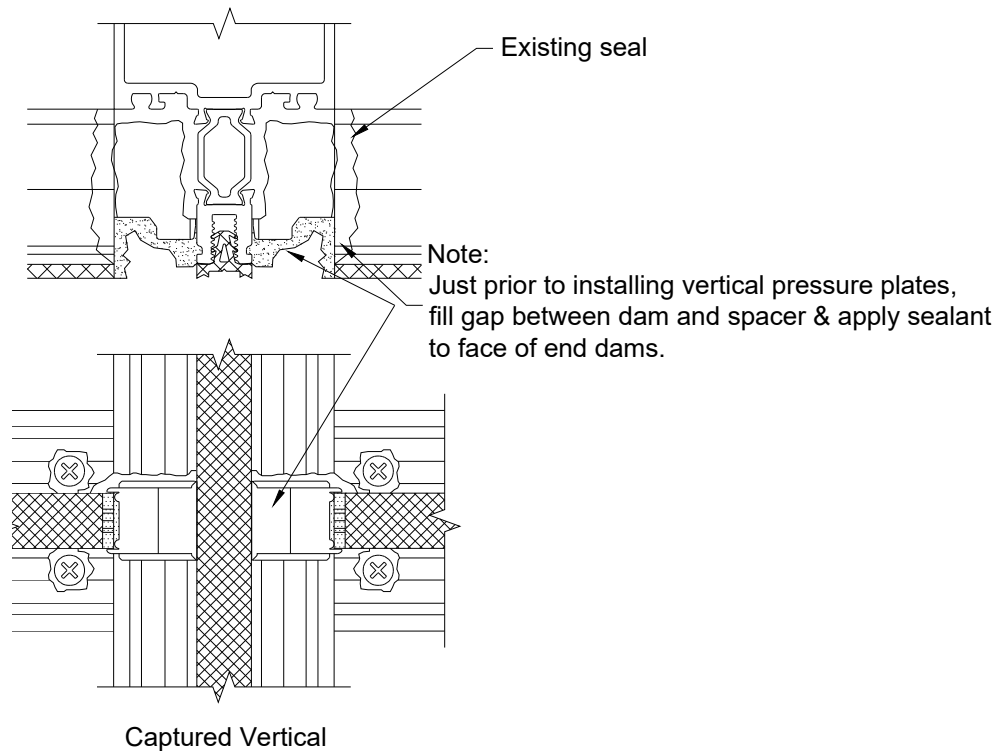

Figure 66: Sealing for Pressure Plates

- 23.6 After removing vertical Temporary Retainers, install vertical Pressure Plates with **FS-236** Fastener at Aluminum Pressure Plates or **FS-284** Fastener at Polyamide Pressure Plates, holding back 1/8" from the ends of the Vertical.
- 23.7 After vertical Pressure Plates are installed on the frame, torque **FS-236** Fastener to **60 in-lbs.** or **FS-284** Fastener to **45 in-lbs.** The use of either a drill motor with a torque limiter or torque wrench can be used. If using a cordless drill, check torque periodically since battery usage will affect the torque setting.
- 23.8 Install vertical Face Covers. Using a wood block to protect Cover, apply with dead blow soft face hammer. Pin the vertical Face Covers once per length as required, concealing pin at a horizontal location. See *Section 24.0* further information for fastening of Covers.
- 23.9 Insert backer rod into cavity at the top of each Vertical. Seal end of Vertical, sloping Sealant back to marry with the perimeter seal. See *Figure 69*.
- 23.10 After removing horizontal Temporary Retainers, center horizontal Pressure Plates in opening, leaving 1/8" gap on each end. Make sure that weep holes are on the top side of the Pressure Plate.

NOTE: Horizontal Pressure Plates and Face Covers run continuous over SSG Mullions, not to exceed (3) lites in length. See *Figure 67* for splicing and sealing instructions.

RELIANCE™ - TC LT Curtain Wall Installation and Glazing Manual

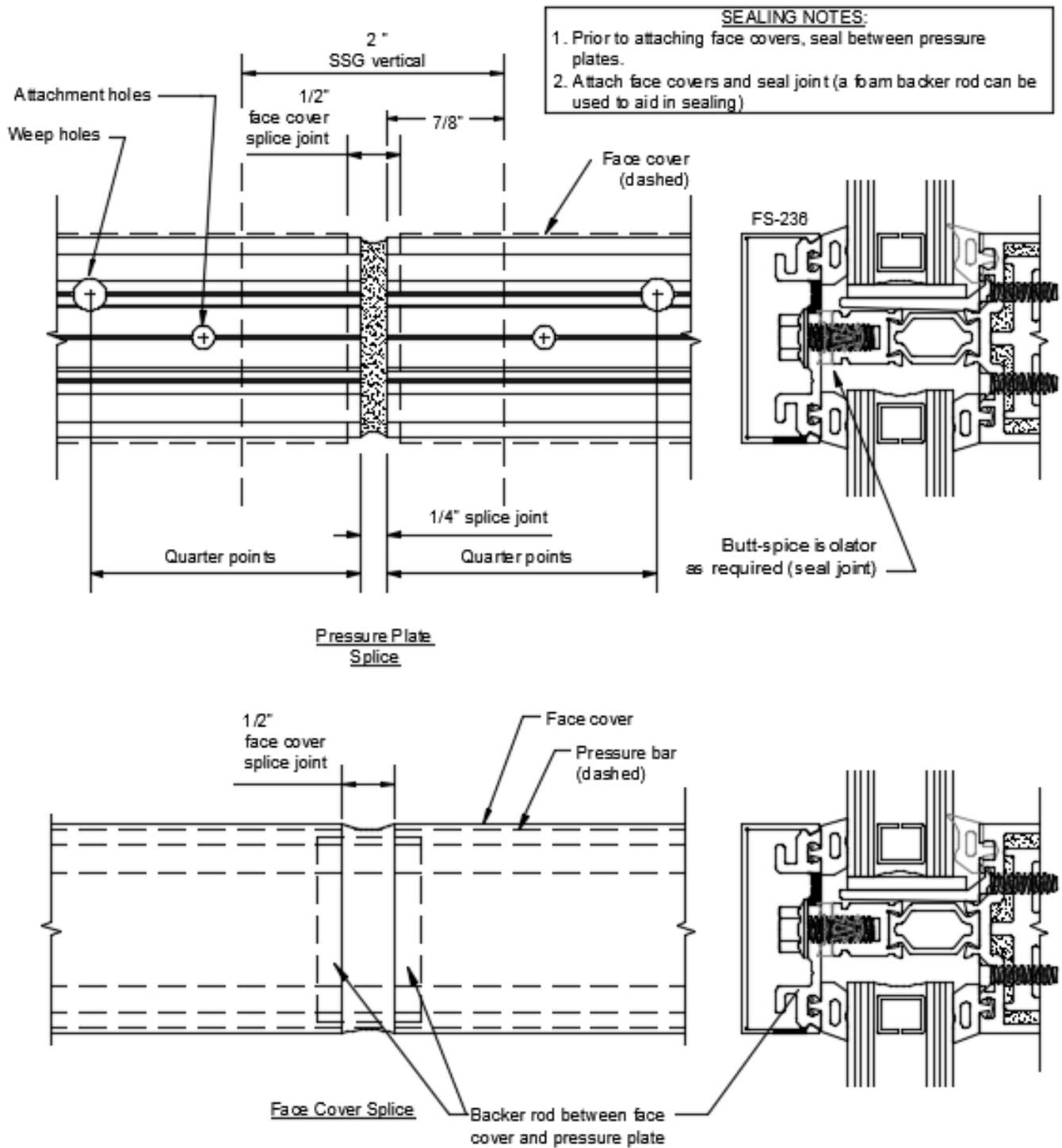

Figure 67: Pressure Plate/Face Cap Splicing & Sealing @ SSG Mullions (Intermediate Horizontal Shown; Head & Sill Similar)

RELIANCE™ - TC LT Curtain Wall Installation and Glazing Manual

- 23.11 After horizontal Pressure Plates are installed on the frame, torque Fasteners as follows: torque **FS-236** Fasteners to **60 in-lbs.** and **FS-284** Fasteners to **50 in-lbs.** The use of either a drill motor with a torque limiter or torque wrench can be used. If using a cordless drill, check torque periodically since battery usage will affect the torque setting.
- 23.12 Seal horizontal Pressure Plates against the vertical Face Covers. Tool sealant into the joint. See *Figure 68*.
- 23.13 Install horizontal Face Covers, leaving an equal gap at each end. Make sure that the weep hole in the Face Cover is on the bottom.
- 23.14 Insert backer rod and seal the top side of the Face Cap at the Expansion Mullion. See *Figure 70*.

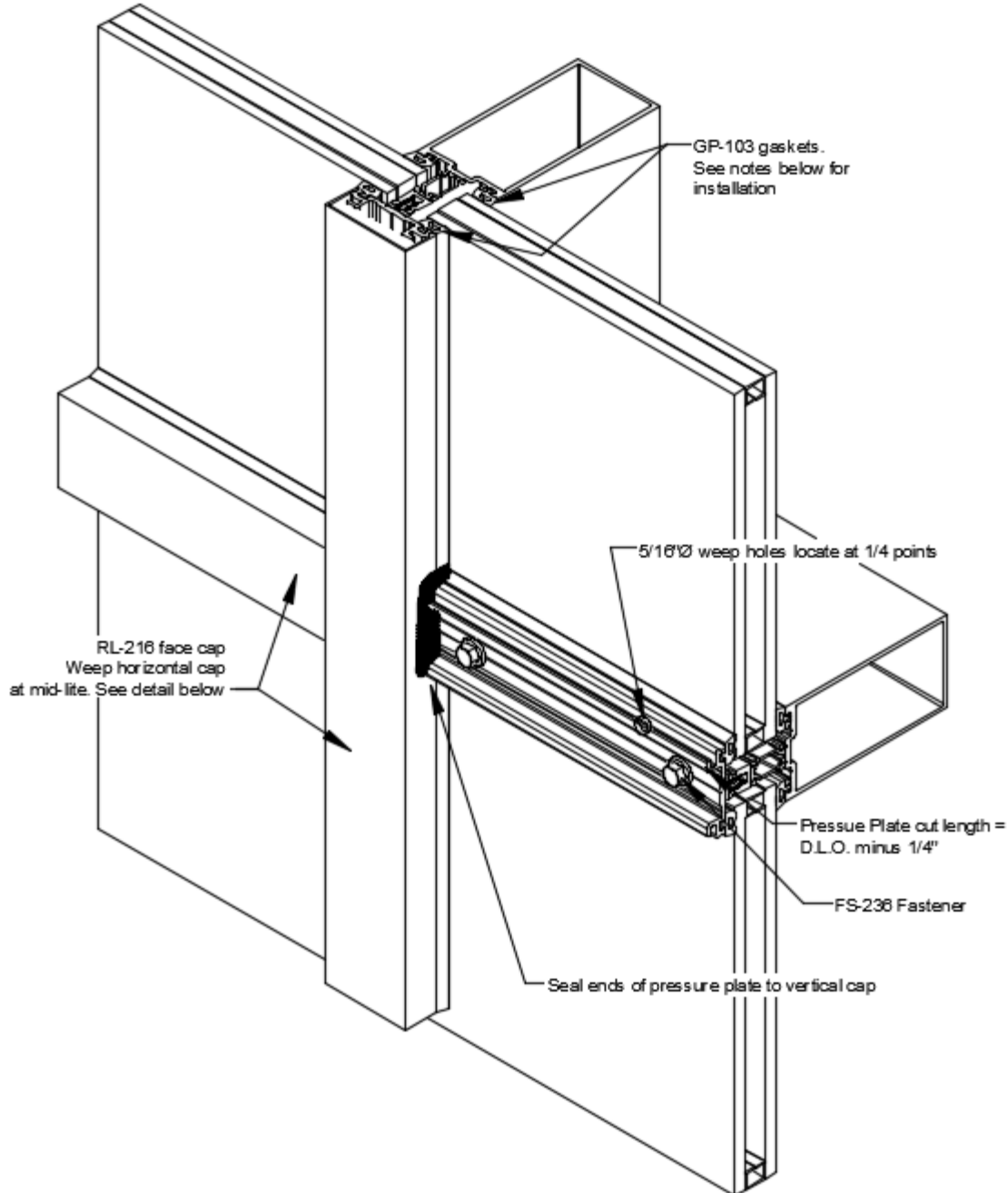

Figure 68: Horizontal Glazing

RELIANCE™ - TC LT Curtain Wall Installation and Glazing Manual

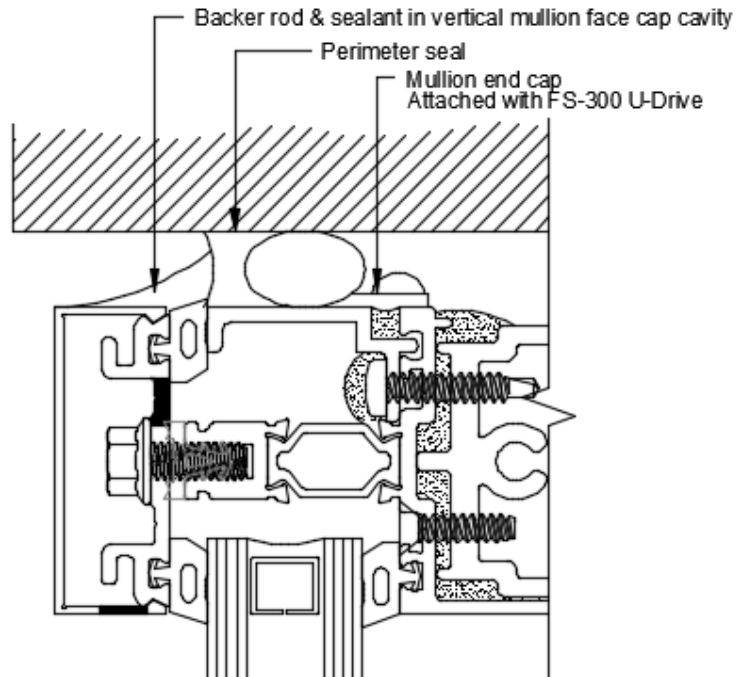

Figure 69: Sealing Top of Captured Verticals

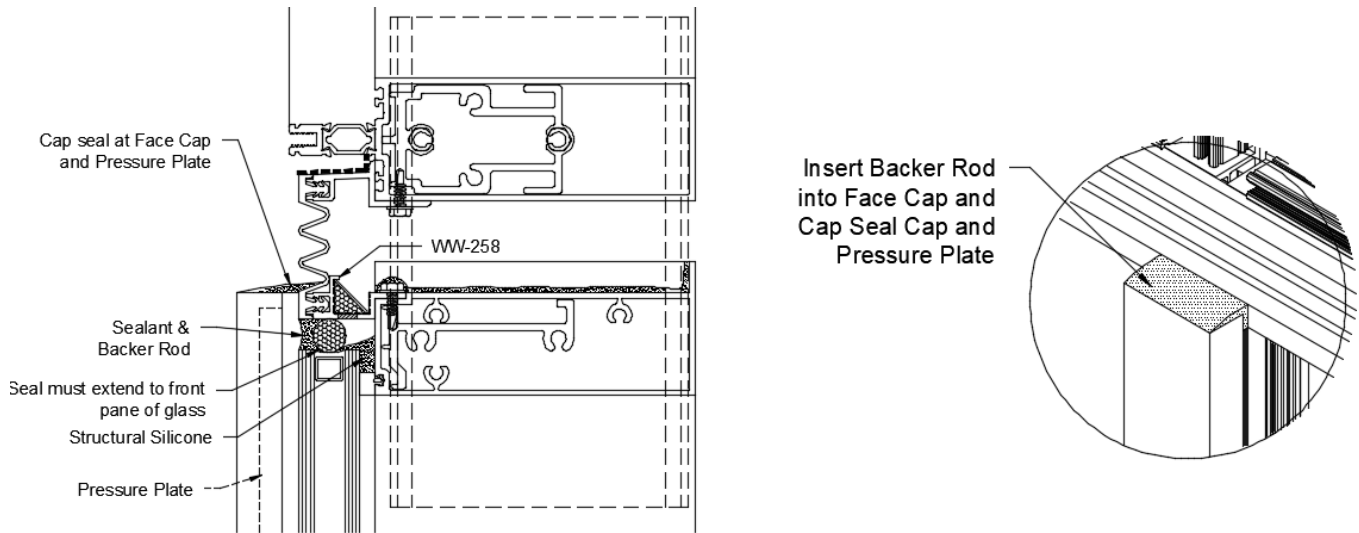

Figure 70: Face Cap / Pressure Plate Seal at Expansion Horizontal

RELIANCE™ - TC LT Curtain Wall Installation and Glazing Manual

24.0 Face Cap Fastening (Safety Fasteners)

24.1 Vertical Face Covers

- The use of safety fasteners to mechanically fasten exterior Face Covers is required for all vertical Covers which run through at Head and Sill, and all Covers, both vertical and horizontal with a depth greater than 3/4".
- Spacing of the safety fastener is dependent on Cover depth, wind load, and snow and ice load conditions:
 - For a standard depth vertical Cover up to 14'-0" in length, a single Fastener on one side of Cover should be sufficient. Location of Fastener in the center of the length is preferable, but not absolute. For aesthetics, it may be desirable to locate Fastener at a Horizontal, so Fastener is concealed underneath the horizontal Face Cover.
 - For vertical Covers which are 4" or greater in depth, two Fasteners, one on each side of Cover, opposing each other, are required. Again, location of Fasteners in the center of the length is preferred but not absolute.
 - For vertical Covers which are 8" or greater in depth, multiple Fasteners, placed on each side of Cover opposing each other, may be required. Harmonics caused by wind vibration must be considered, as well as lateral wind load on the Cover itself, wind load deflection of Mullion and Cover, and snow and ice load.

24.2 Horizontal Face Covers

- For a horizontal Cover up to 8'-0" in length and up to 4" deep, a single Fastener located at the center of the length on the top side of the Cover should be sufficient. Location of the horizontal Fasteners on the top side is the best practice.
- For horizontal Covers greater than 8'-0" or deeper than 4", multiple Fasteners may be required. Harmonics caused by wind vibration must be considered, as well as wind load deflection of the Horizontal and Cover, and snow and ice load.
- See *Figure 71* for three common Pressure Plate and Face Cap installations. Other custom profiles may be used and attached following this method. Type 1 may be used up to 4" in depth. Type 2 and 3 are for Caps 4" or greater, with type 3 being preferred for any Cap or Cap assembly greater than 8". All Caps shown below will be attached using the **FS-317** Roll Pin. Drill Cap and Pressure Plate with a 1/8" (.125") clearance hole.

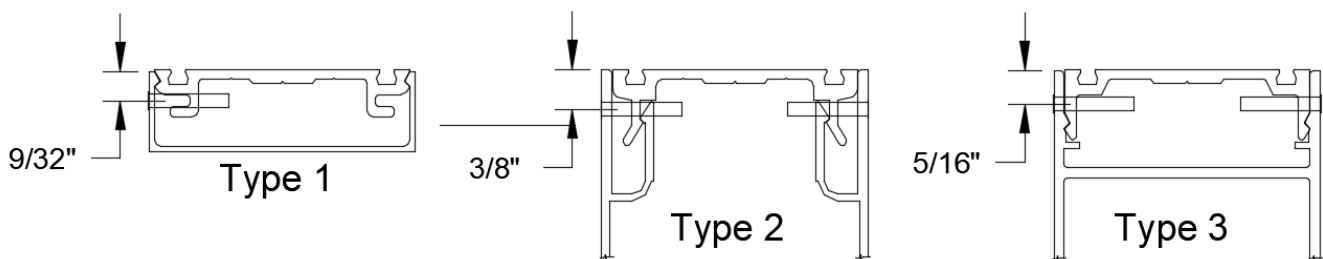

Figure 71: Face Cover Fabrication

RELIANCE™ - TC LT Curtain Wall Installation and Glazing Manual

REGLAZING

25.0 Reglazing Procedure

- 25.1 Reglazing must be done from the exterior. Carefully remove Face Covers surrounding the lite of glass to be deglazed. See *Figure 72*.
- 25.2 Remove vertical and horizontal Pressure Plates adjacent to lite that must be replaced. Temporarily clip surrounding glass in place with **WW-162-01** Temporary Glazing Retainers. Torque to **50 in-lbs**. Refer to *Step 21.2* for instructions on locating Retainers.
- 25.3 Remove lite of glass and existing Gaskets from opening. Clean debris and sealant from aluminum framing members and Pressure Plates.
- 25.4 Install new Gaskets into framing and install new lite of glass.

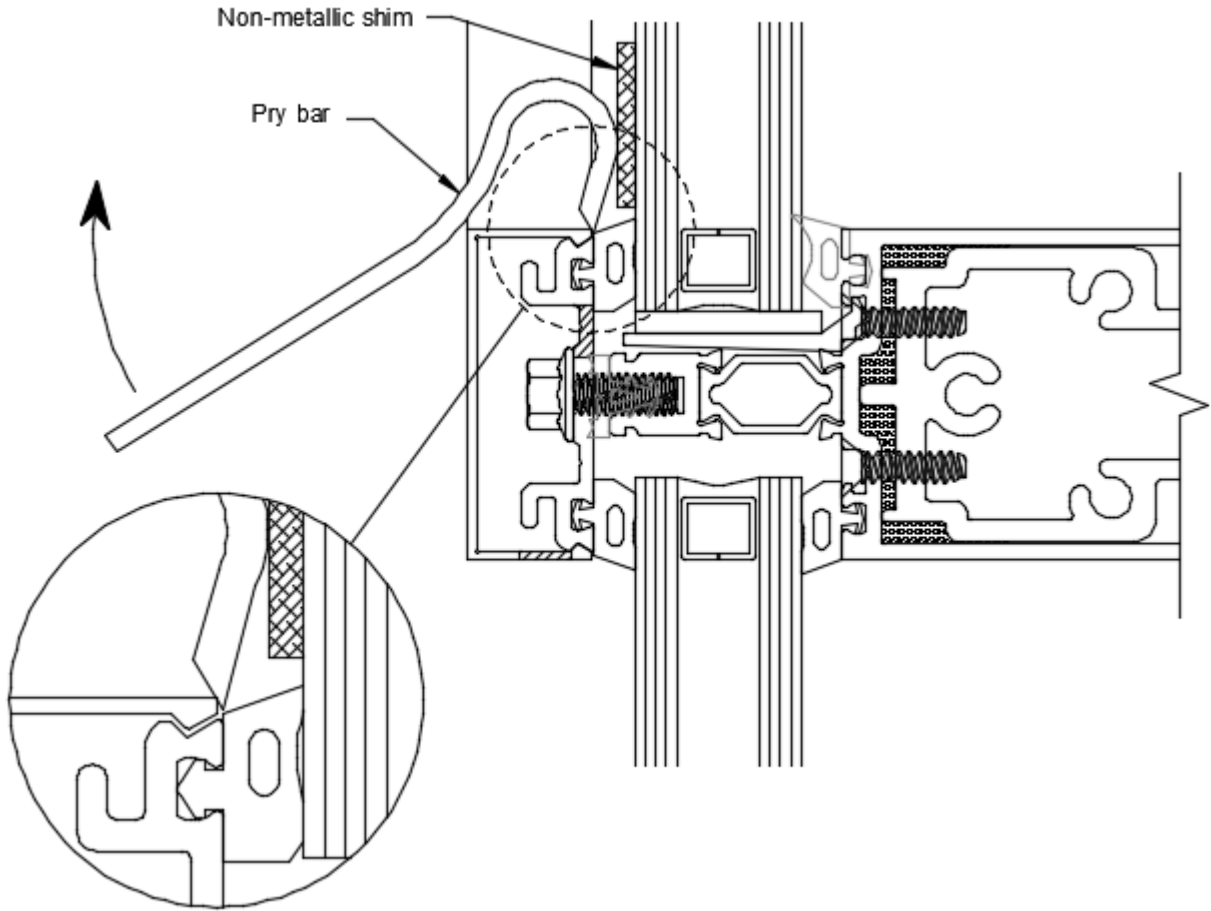

Figure 72: Deglazing

RELIANCE™ - TC LT Curtain Wall Installation and Glazing Manual

CORNERS

26.0 Captured OS 90° Corner Assembly

Fabricate and assemble as shown below. *Figure 73* shows the basic layout of the standard one-piece Corner Mullion assembly. This detail is for general reference and does not necessarily reflect all conditions. For specific assembly, sealing and anchoring notes, refer to approved shop drawings.

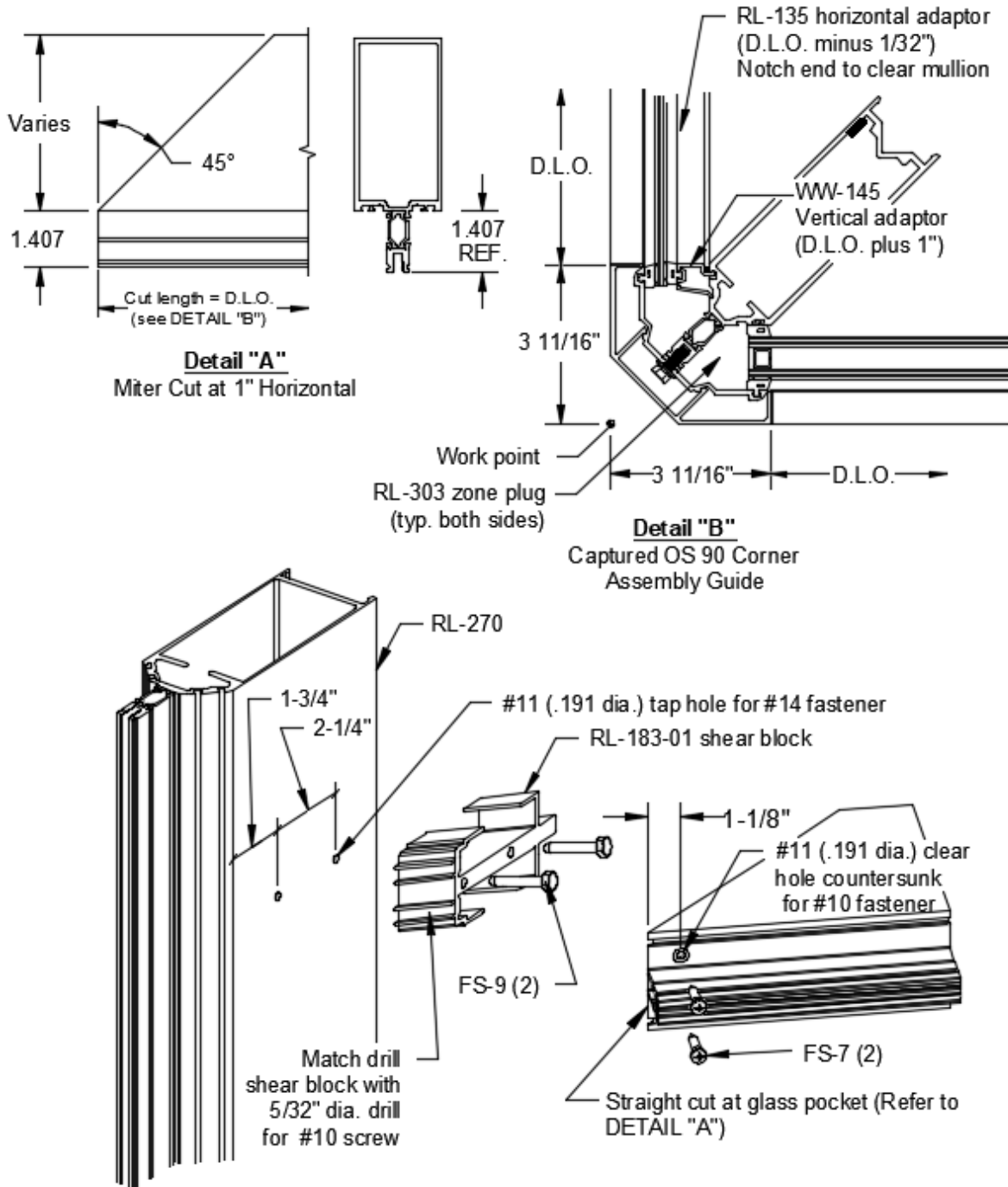

Figure 73: Outside 90° Corner Assembly Guide, Captured

RELIANCE™ - TC LT Curtain Wall Installation and Glazing Manual

27.0 Captured OS 135° Corner Assembly

Fabricate and assemble as shown below. *Figure 74* shows the basic layout of the standard one-piece Corner Mullion assembly. This detail is for general reference and does not necessarily reflect all conditions. For specific assembly, sealing and anchoring notes, refer to approved shop drawings.

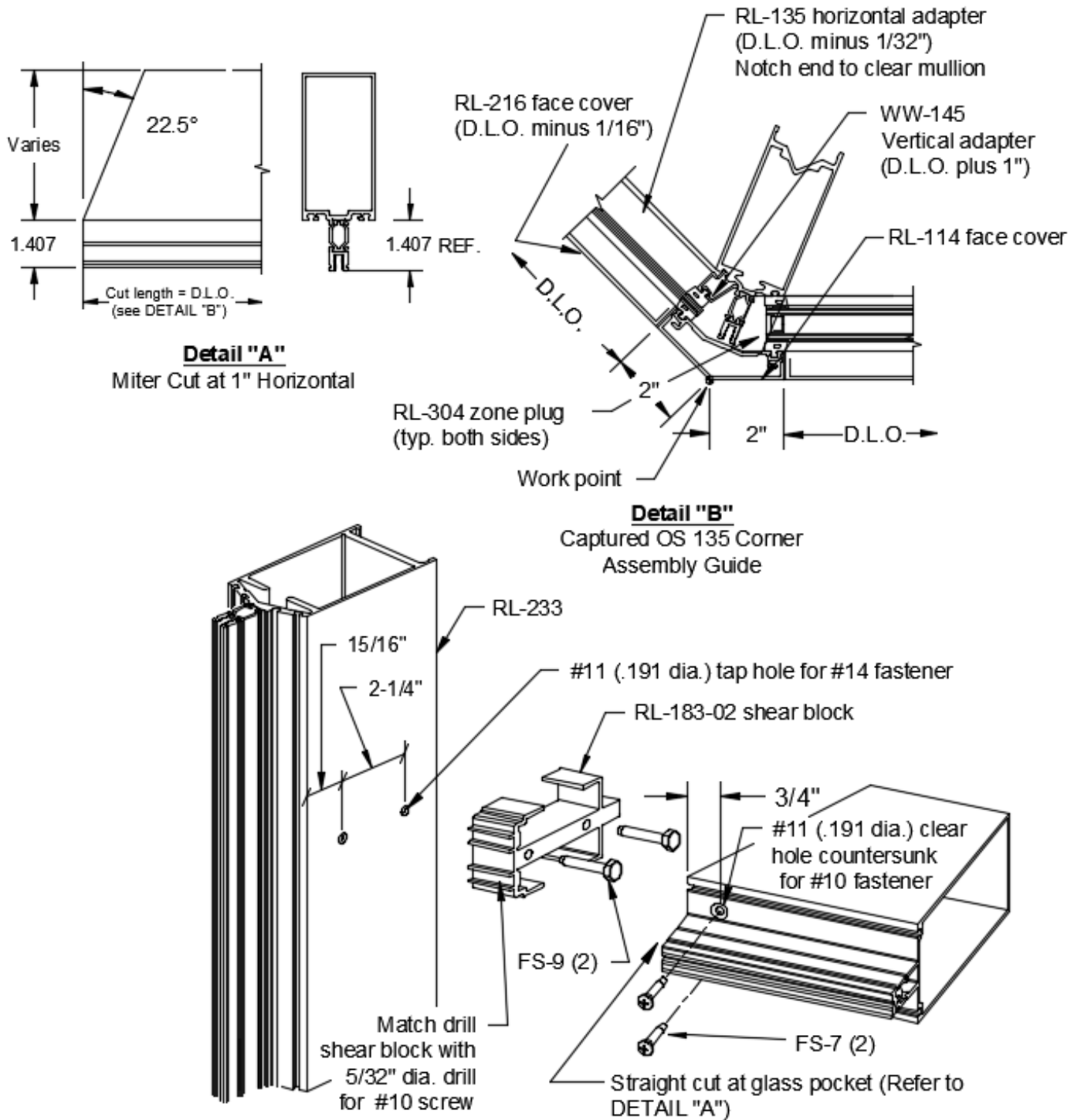

Figure 74: Outside 135° Corner Assembly Guide, Captured

1-866-OLDCASTLE (653-2278)

OBE.com

Version: 2023-1013

Copyright © 2023 Oldcastle BuildingEnvelope®
All rights reserved.

™ © Trademarks of Oldcastle BuildingEnvelope and its affiliated companies or respective owners.

RELIANCE™ - TC LT Curtain Wall Installation and Glazing Manual

28.0 SSG OS 90° Corner Assembly

Fabricate and assemble as shown in *Figure 75*. This detail shows the basic layout of the standard one-piece Corner Mullion assembly. This detail is for general reference and does not necessarily reflect all conditions. For specific assembly, sealing and anchoring notes, refer to approved shop drawings.

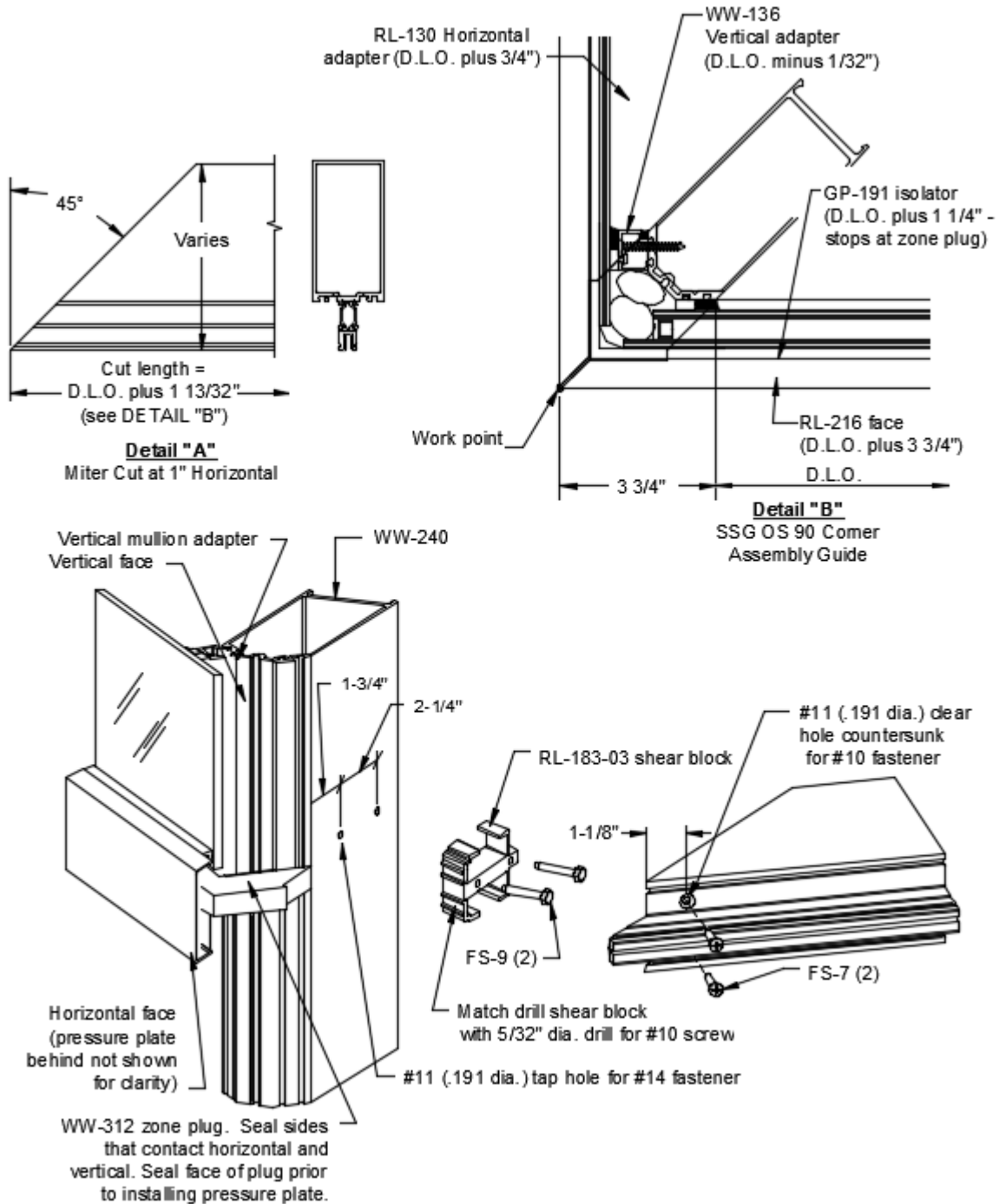

Figure 75: Outside 90° Corner Assembly Guide, SSG

RELIANCE™ - TC LT Curtain Wall Installation and Glazing Manual

29.0 SSG OS 135° Corner Assembly

Fabricate and assemble as shown below. *Figure 76* shows the basic layout of the standard one-piece Corner Mullion assembly. This detail is for general reference and does not necessarily reflect all conditions. For specific assembly, sealing and anchoring notes, refer to approved shop drawings.

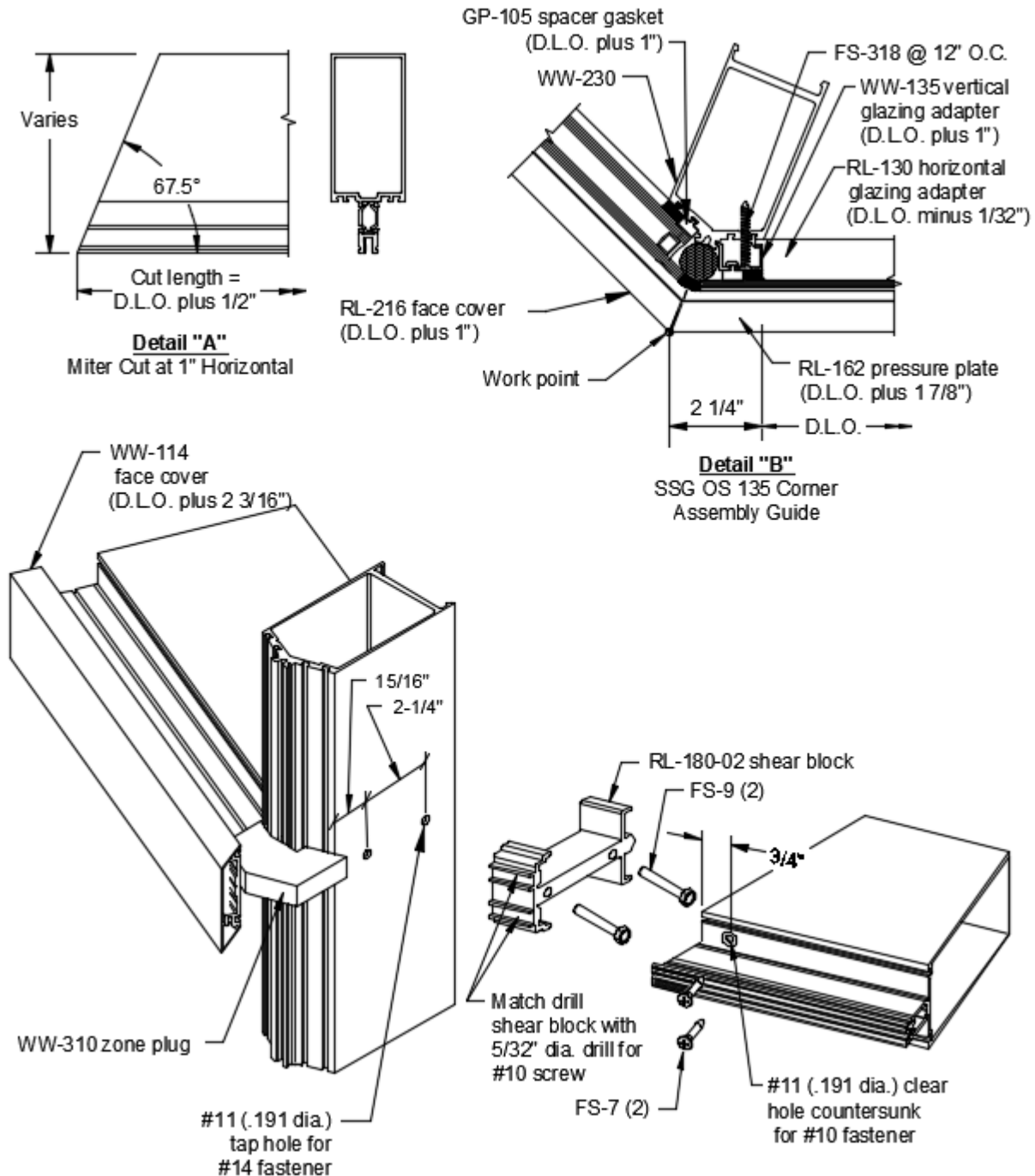

Figure 76: Outside 135° Corner Assembly Guide, SSG

RELIANCE™ - TC LT Curtain Wall Installation and Glazing Manual

30.0 SSG IS 90° Corner Assembly

Fabricate and assemble as shown in *Figure 77*. This detail shows the basic layout of the standard one-piece Corner Mullion assembly. This detail is for general reference and does not necessarily reflect all conditions. For specific assembly, sealing and anchoring notes, refer to approved shop drawings.

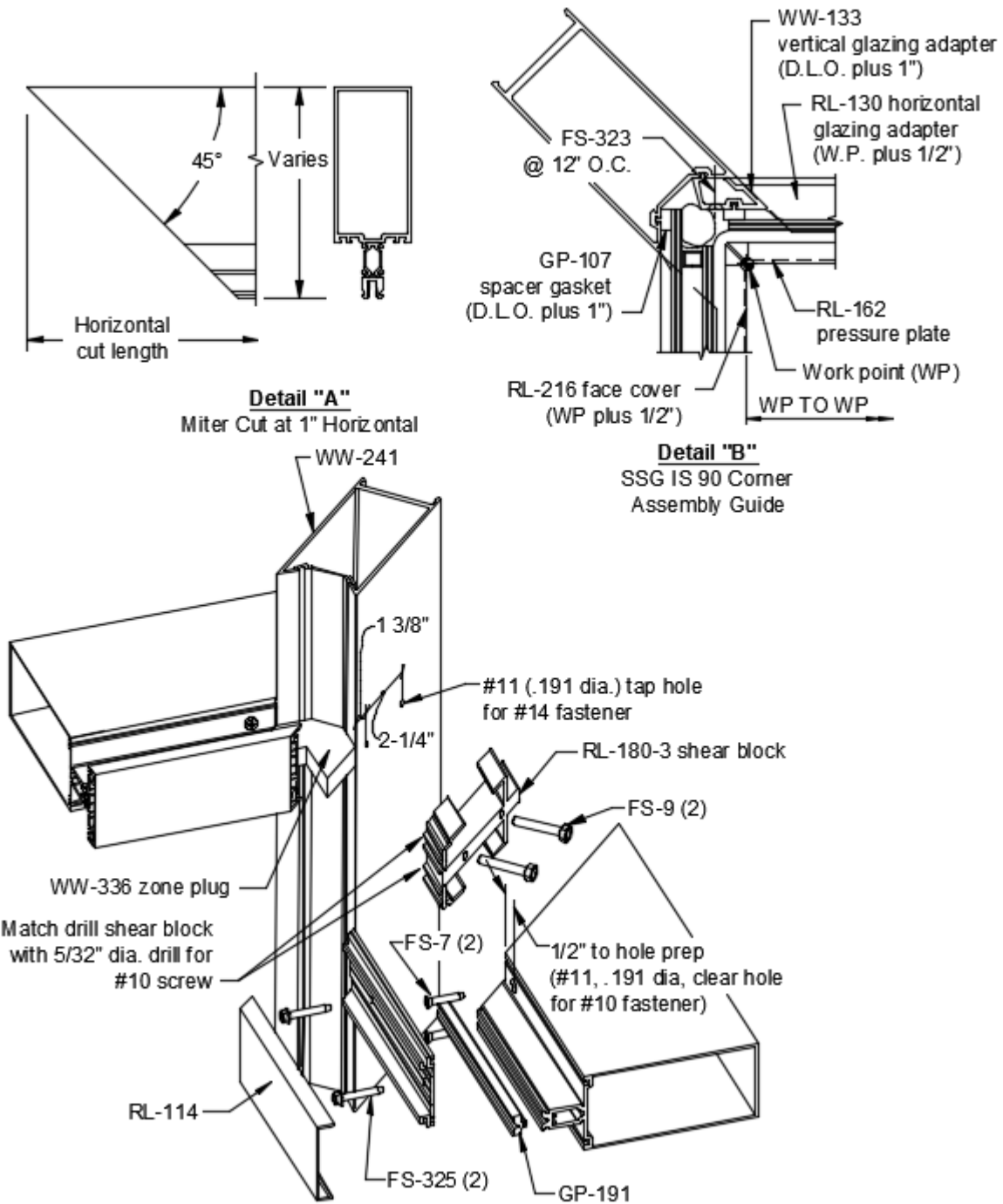

Figure 77: Inside 90° Corner Assembly Guide, SSG

1-866-OLDCASTLE (653-2278)

OBE.com

Version: 2023-1013

Copyright © 2023 Oldcastle BuildingEnvelope®
All rights reserved.

™ © Trademarks of Oldcastle BuildingEnvelope and its affiliated companies or respective owners.

DOORS

31.0 Door framing

Fabricate and assemble as shown in *Figure 78*. Refer to *Figure 10* on page 18 for the fabrication of the **RL-122** Pocket Filler.

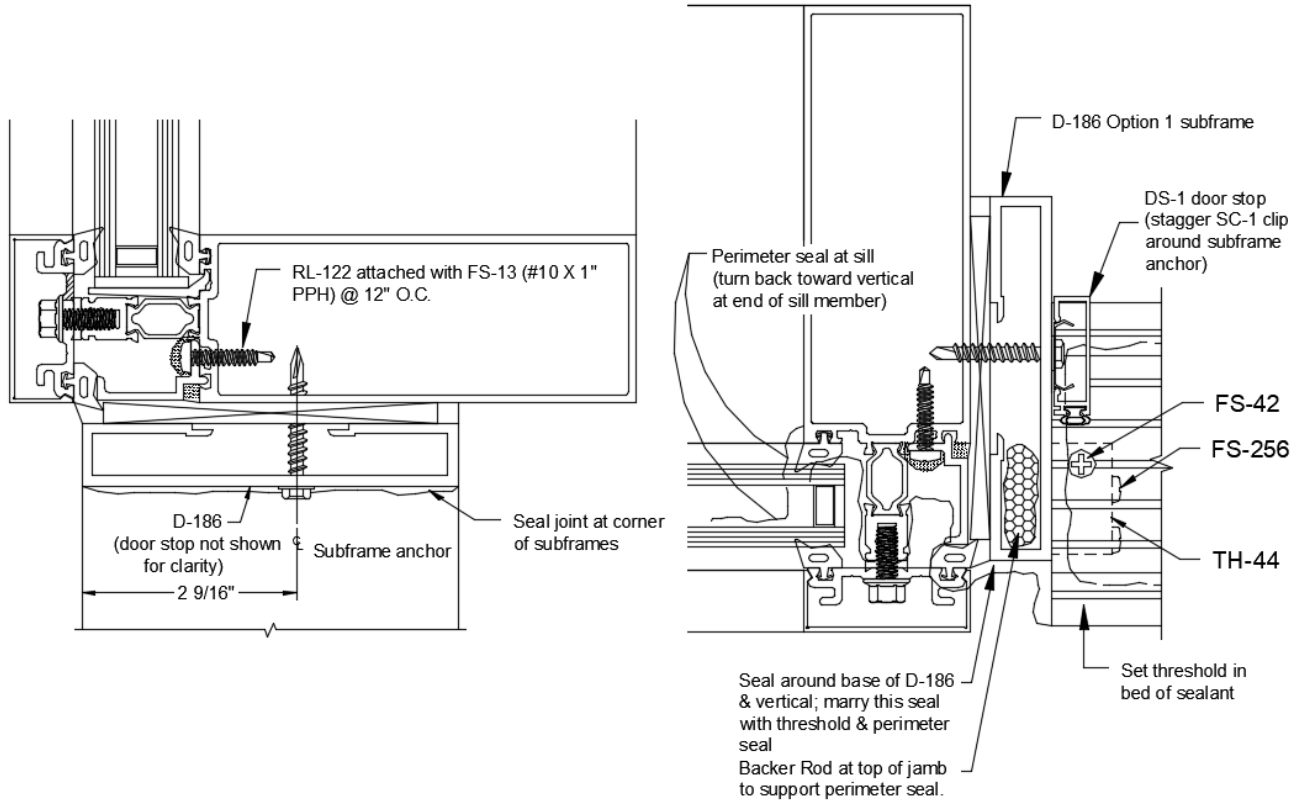



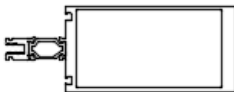

Figure 78: Door Assembly Guide

RELIANCE™ - TC LT Curtain Wall Installation and Glazing Manual





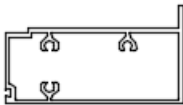
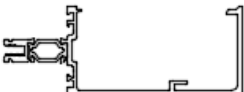

PARTS LIST

Parts not shown to scale.

2" x 6" SYSTEM

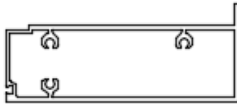
<p>RL-404</p> 	<p>SSG Mullion</p>	<p>RL-430</p> 	<p>Heavy Mullion</p>
<p>RL-420</p> 	<p>Captured Mullion</p>	<p>WW-484</p> 	<p>Lower Expansion Horizontal</p>
<p>RL-425</p> 	<p>Head / Sill Roll Over/Under Horizontal</p>		

2" x 7-1/4" SYSTEM

<p>RL-504</p> 	<p>SSG Mullion</p>	<p>RL-535</p> 	<p>Optional Upper Expansion Horizontal</p>
<p>RL-520</p> 	<p>Captured Mullion</p>	<p>WW-584</p> 	<p>Lower Expansion Horizontal</p>
<p>RL-525</p> 	<p>Head / Sill Roll Over/Under Horizontal</p>	<p>WW-259</p> 	<p>Interior Trim for RL-535</p>
<p>RL-530</p> 	<p>Heavy Mullion</p>		

1-866-OLDCASTLE (653-2278)

OBE.com











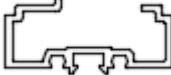

Version: 2023-1013

Copyright © 2023 Oldcastle BuildingEnvelope®
All rights reserved.

™ ® Trademarks of Oldcastle BuildingEnvelope and its affiliated companies or respective owners.

RELIANCE™ - TC LT Curtain Wall Installation and Glazing Manual

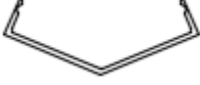
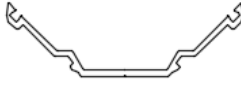
SHARED EXTRUSIONS

AN-1 	3/4" x 3/4" x 1/8" Angle	RL-124 	Glazing Adaptor
AN-2 	1" x 1" x 1/8" Angle	RL-131 	Glazing Adaptor
AW-132 	Glazing Adaptor	RL-135 	Glazing Adaptor
CW-823 	Mullion Filler	RL-142 	SSG to Captured Glazing Adaptor
RL-125 	Thermal Pocket Filler	RL-162-03 	Standard Pressure Plate
RL-113 	90° Face Cap	RL-163-03 	Polyamide Pressure Plate
RL-114 	135° Face Cap	RL-164 	90° Pressure Plate
RL-122 	Pocket Filler	RL-165 	135° Pressure Plate

1-866-OLDCASTLE (653-2278)

Version: 2023-1013











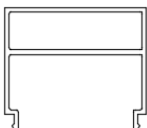
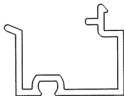

Copyright © 2023 Oldcastle BuildingEnvelope®
All rights reserved.

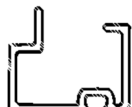
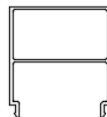
™ © Trademarks of Oldcastle BuildingEnvelope and its affiliated companies or respective owners.

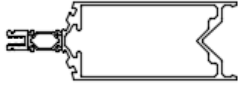
OBE.com

RELIANCE™ - TC LT Curtain Wall Installation and Glazing Manual

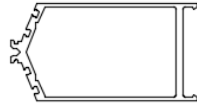
SHARED EXTRUSIONS, Continued

RL-216 	Face Cap	WW-133 	1/4" Glazing Adaptor
RL-220 	Mullion Filler	WW-135 	1/4" Glazing Adaptor
RL-221 	Mullion Filler	WW-136 	1/4" Glazing Adaptor
RL-222 	Mullion Filler	WW-145 	1/4" Glazing Adaptor
RL-233 	Outside 135° Vertical Mullion	WW-220 	Mullion Filler
RL-257 	Pocket Filler	WW-221 	Mullion Filler
RL-270 	Outside 90° Vertical Mullion	WW-230 	135° corner Mullion
WW-258 	Gasket Retainer	WW-237 	Horizontal Filler

RELIANCE™ - TC LT Curtain Wall Installation and Glazing Manual

SHARED EXTRUSIONS, Continued

WW-240 	Outside 90° Corner Mullion
---	----------------------------

WW-241 	Inside 90° Corner Mullion
--	---------------------------

REINFORCEMENT

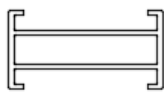
RL-192 	Reinforcement for RL-420
---	--------------------------

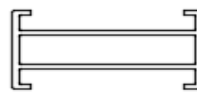
RL-195 	Reinforcement for RL-504 & RL-530
--	-----------------------------------

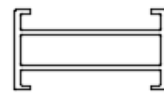
RL-193 	Reinforcement for RL-404 & RL-430
---	-----------------------------------

RS-12 	Reinforcing Steel 1/2" x 3"
---	--------------------------------

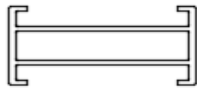
RL-194 	Reinforcement for RL-520
---	--------------------------

RS-13 	Reinforcing Steel 1/2" x 4"
---	--------------------------------

FASTENERS

FS-7 	#10 x 3/4" Phillips FL Hd B Pt
---	-----------------------------------

FS-55 	#10 x 1/2" Phillips Pan Hd AB Pt
---	-------------------------------------

FS-9 	#14 x 1-1/2" Hex Hd B Pt
---	-----------------------------

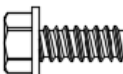
FS-108 	#14 x 5/8" Hex Washer Hd B Pt
--	----------------------------------

FS-13 	#10 x 1" Phillips Pan Hd TEK Pt
--	------------------------------------

FS-115 	#10 x 1" Phillips Pan Hd B Pt
--	----------------------------------

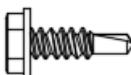
FS-19 	#10 x 5/8" Hex Washer Hd TEK Pt
--	------------------------------------

FS-119 	#10 x 1-3/8" Phillips FL Hd B Pt
--	-------------------------------------

1-866-OLDCASTLE (653-2278)

OBE.com





Version: 2023-1013



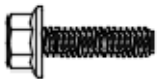
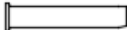

Copyright © 2023 Oldcastle BuildingEnvelope®
All rights reserved.

™ © Trademarks of Oldcastle BuildingEnvelope and its affiliated companies or respective owners.

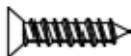

RELIANCE™ - TC LT Curtain Wall Installation and Glazing Manual



FASTENERS, Continued

FS-201 	#10 x 2" Phillips FL Hd A Pt
FS-236 	1/4"-20 x 5/8" SS Hex Washer Hd MS
FS-284 	1/4"-20 x 7/8" SS Hex Washer Hd MS
FS-317 	1/8" x 3/4" SS Headed Spring Pin
FS-318 	#12 x 1-3/4" Phillips FL Hd A Pt
FS-320 	M4 x 16mm U- Drive

FS-323 	#12 x 1" Phillips FL Hd A Pt
FS-336 	1/4"-20 x 1-1/8" Hex Washer Hd KF Pt
	1/4" Flat Washer
	1/4"-20 x 2-1/2" Hex Hd Bolt
	1/4"-20 x 3" Hex Hd Bolt

GASKETS AND GLAZING MATERIALS

CW-2101 	3/16" x 1/2" Setting Block
GP-103 	Glazing Gasket 1/4" Face Clearance

GP-105 	Spacer Gasket
GP-106 	Offset Spacer Gasket

1-866-OLDCASTLE (653-2278)

OBE.com





Version: 2023-1013







Copyright © 2023 Oldcastle BuildingEnvelope®
All rights reserved.

™ ® Trademarks of Oldcastle BuildingEnvelope and its affiliated companies or respective owners.

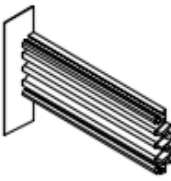

RELIANCE™ - TC LT Curtain Wall Installation and Glazing Manual

GASKETS AND GLAZING MATERIALS, continued

GP-114 	1/8" x 1-1/8" x 4" Side Block
GP-117 	Glazing Gasket 3/16" Face Clearance
GP-118 	Glazing Gasket 5/16" Face Clearance
GP-144-02 	Expansion Gasket 90° OS Seal
GP-145 	SSG Spacer Gasket
GP-146 	SSG Captured Gasket

GP-191 	Isolator Gasket
GP-192 	1/8" x 1" x 4" Setting Block
GP-142 	Isolator Gasket
GP-144 	Expansion Gasket
GP-144-01 	Expansion Gasket Jamb Seal
GP-32007 	Bulb Gasket for Splice Cover

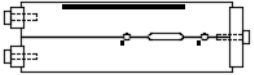
SHARED ACCESSORIES

DJ-117 	Drill Jig
HP-1004p 	Weep Baffle

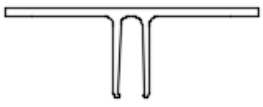
SPW-295 	Weep Baffle Retainer
RL-102-03 	"T" Anchor RL-404 & RL-430

1-866-OLDCASTLE (653-2278)

OBE.com







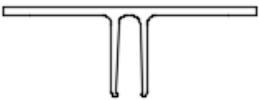

Version: 2023-1013

Copyright © 2023 Oldcastle BuildingEnvelope®
All rights reserved.

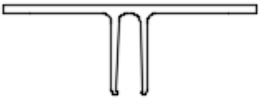
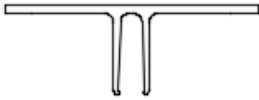
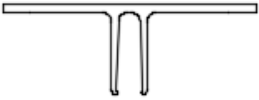
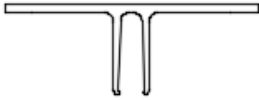
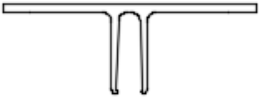
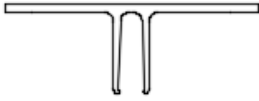
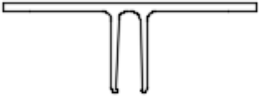
™ ® Trademarks of Oldcastle BuildingEnvelope and its affiliated companies or respective owners.

RELIANCE™ - TC LT Curtain Wall Installation and Glazing Manual

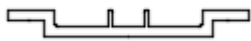
SHARED ACCESSORIES, continued

RL-102-04 	"T" Anchor RL-504 & RL-530	RL-103-06 	"F" Anchor RL-520
RL-102-05 	"T" Anchor RL-420	WW-102-05 	"T" Anchor WW-240
RL-102-06 	"T" Anchor RL-520	WW-102-06 	"T" Anchor WW-230
RL-102-07 	"T" Anchor RL-270	WW-102-07 	"T" Anchor WW-241
RL-102-08 	"T" Anchor RL-233	WW-104-02 	Shear Block Anchor
RL-103-03 	"F" Anchor RL-404 & RL-430	RL-108-01 	Sunshade Anchor
RL-103-04 	"F" Anchor RL-504 & RL-530	WW-2223-02 	Jamb Anchor Plate
RL-103-05 	"F" Anchor RL-420	RL-127-01 	Setting Block Chair

1-866-OLDCASTLE (653-2278)

OBE.com







Version: 2023-1013

Copyright © 2023 Oldcastle BuildingEnvelope®
All rights reserved.

™ © Trademarks of Oldcastle BuildingEnvelope and its affiliated companies or respective owners.

RELIANCE™ - TC LT Curtain Wall Installation and Glazing Manual

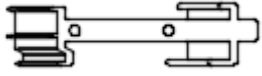
SHARED ACCESSORIES, continued

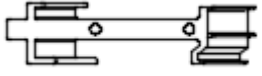
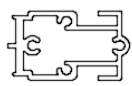
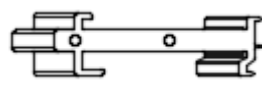
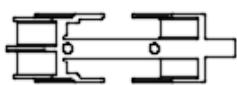
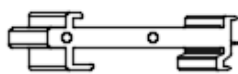
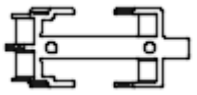
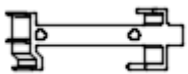
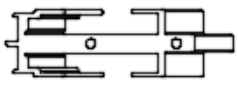
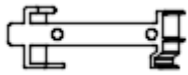
RL-171-01 	Splice Sleeve RL-233	RL-185-01 	Optional Shear Block
RL-172-01 	Splice Sleeve RL-270	WW-276-01 	Shear Block WW-484 & WW-584
WW-190-01 	Splice Sleeve WW-230	WW-283-01 	Shear Block Outside 90°
WW-191-01 	Splice Sleeve WW-240	WW-283-02 	Shear Block Outside 90°
RL-182-01 	Standard Shear Block	WW-283-03 	Shear Block Inside 90°
RL-183-01 	Shear Block Outside 90° Corners	WW-283-04 	Shear Block Inside 90°
RL-183-02 	Shear Block Outside 135° Corners	WW-283-05 	Shear Block Outside 135°
RL-183-03 	Shear Block Inside 90° Corners	WW-283-06 	Shear Block Outside 135°

1-866-OLDCASTLE (653-2278)

OBE.com













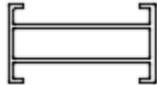

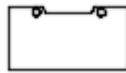
Version: 2023-1013

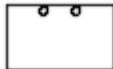
Copyright © 2023 Oldcastle BuildingEnvelope®
All rights reserved.

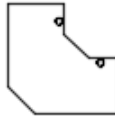
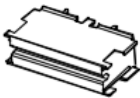
™ ® Trademarks of Oldcastle BuildingEnvelope and its affiliated companies or respective owners.

RELIANCE™ - TC LT Curtain Wall Installation and Glazing Manual

SHARED ACCESSORIES, continued

RL-192-01 	Splice Sleeve RL-420	RL-303 	Zone Dam Outside 90° Corner
RL-193-01 	Splice Sleeve RL-404 & RL-430	RL-304 	Zone Dam Outside 135° Corner
RL-194-01 	Splice Sleeve RL-520	RL-325 	End Cap Captured Mullion
RL-195-01 	Splice Sleeve RL-504 & RL-530	RL-327 	End Cap SSG Mullion
WW-202-01 	Splice Sleeve WW-241	RL-328 	End Cap Outside 90° Corner
RL-300 	SSG Zone Bridge	RL-329 	End Cap Outside 135° Corner
RL-302 	Zone Plug	WW-310 	SSG Bridge Outside 135° Corner
WW-336 	Zone Plug Inside 90° Corner	WW-312 	SSG Bridge Outside 90° Corner

RELIANCE™ - TC LT Curtain Wall Installation and Glazing Manual

Shared Accessories, continued

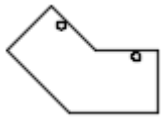
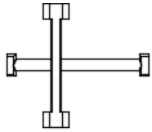
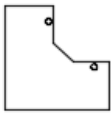
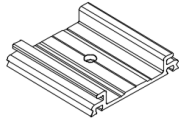
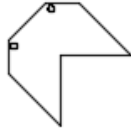
<p>WW-321</p> 	<p>SSG Mullion Cap Outside 135° Corner</p>	<p>SPW-PP-3</p> 	<p>Temporary Glazing Retainer at SSG Verticals</p>
<p>WW-323</p> 	<p>SSG Mullion Cap Outside 90° Corner</p>	<p>WW-162-01</p> 	<p>Temporary Glazing Retainer at Captured</p>
<p>WW-337</p> 	<p>SSG Mullion Cap Inside 90° Corner</p>		

RELIANCE™ - TC LT Curtain Wall Installation and Glazing Manual

Installation Checklist

- Before installation, verify correct steel reinforcing is attached properly and located correctly.
- Verify pressure plates fastener holes 1-1/2" from the ends. Horizontal pressure plates should have two 5/16" weep holes at quarter points.
- Horizontal face covers should have one 5/16" weep hole at the center of the cover.
- Bond breaker tape should be applied to prevent 3 sided adhesion. Examples: mullion splice sleeve, cover sleeve, etc., prior to sealing.
- End caps should be fully sealed and fastened to both ends of all vertical mullions.
- Nylon Slip Pads should be used between all winD.L.O.ad/deadload anchors and mullions.
- Sealant should be applied around the front of the shear blocks just prior to attachment of the horizontal mullions to the shear blocks at all vertical/horizontal joints.
- Backer rod and 1/4" minimum caulk joint at jambs head, and sill.
- Verify all horizontal/vertical intersections have joint plugs. Apply sealant to surfaces of joint plug and insert between horizontal/vertical. Tool excess sealant.
- Sealant over horizontal/vertical mullion joint seam, and any exposed horizontal shear block fasteners.
- Glazing adapters applied with a continuous bead of sealant in the mullion glazing race before inserting and fastening the adapters. Also, ensure the adapter to end cap has been sealed.
- Interior vertical gaskets cut to D.L.O. + 1/4" per foot + 1". Interior horizontal gaskets should be cut to D.L.O. + 1/4" per foot
- After interior gaskets are installed, pull both horizontal and vertical gaskets out of the glazing race at the corners and seal the reglet 3" over the horizontal and 3" up the vertical mullion. Press the gaskets back into the races and seal the seam at the vertical/horizontal gasket intersection. Do not allow sealant to cure before setting glass.
- Setting blocks placed on the horizontals at their appropriate locations for the size of the glass. The setting blocks should not obstruct the path of water to the weep holes in the pressure plates.
- Side blocks positioned on both sides of each lite of glass at the centerline of the vertical daylight opening. Additional side blocks are required for seismic conditions.
- Just prior to application of the vertical pressure plates, apply sealant to the face of the joint plugs.
- Horizontal pressure plates should be applied after vertical pressure plates.
- Pressure plate fasteners torqued per appropriate application