



**Oldcastle** BuildingEnvelope®

*SIGNATURE SERIES UNIT WALL  
INSTALLATION MANUAL*

*Note: Installation Manual is product specific:*

**FOR REFERENCE ONLY**

# SIGNATURE SERIES UNIT WALL INSTALLATION MANUAL

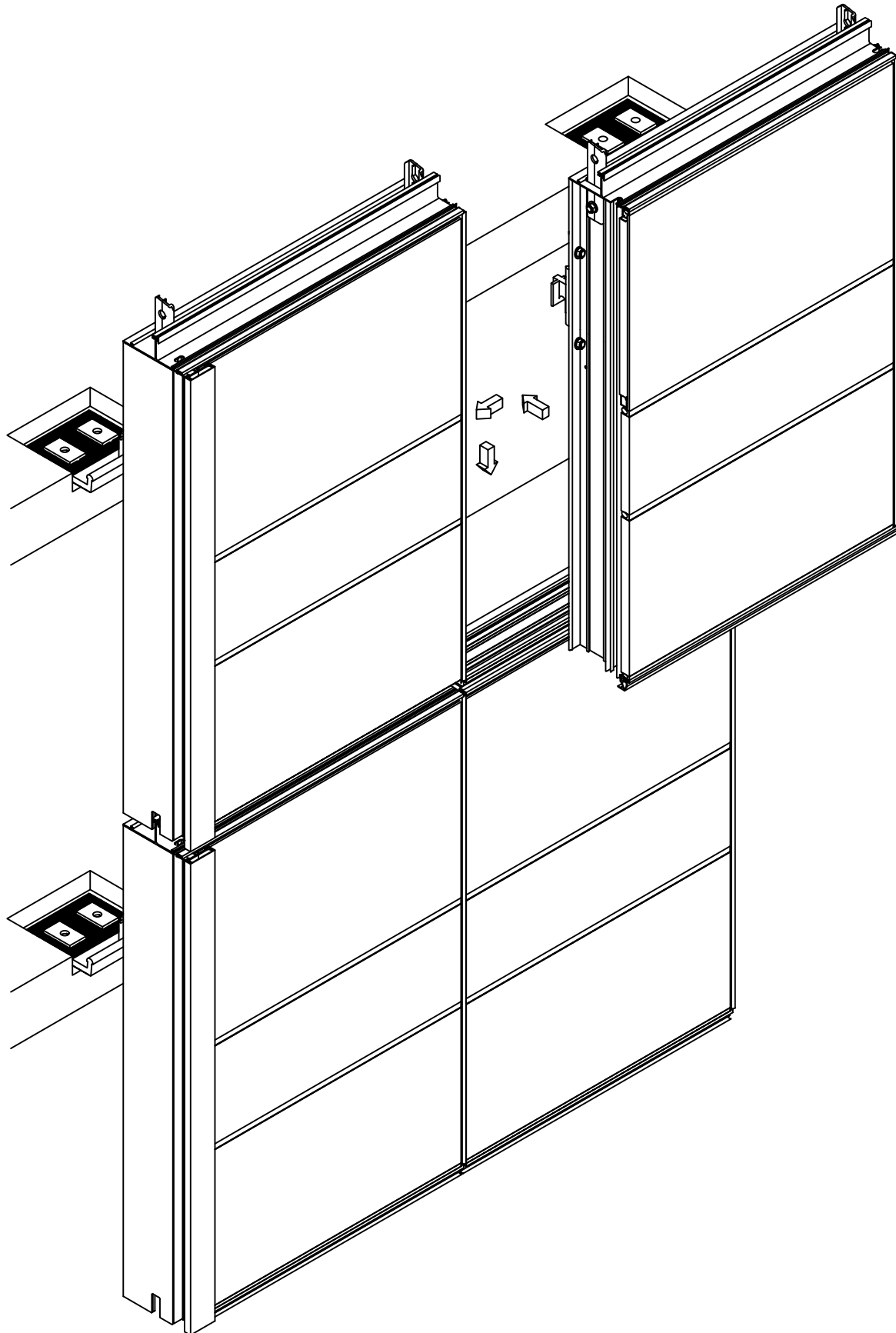

# SIGNATURE SERIES UNIT WALL INSTALLATION MANUAL

## TABLE OF CONTENTS

	SHEET
GENERAL INFORMATION	
Product Use	3
Protection and Storage	3
Check Material	3
Field Conditions	4
Cleaning Materials	4
Expansion Joints	4
LAYOUT MULLION AND ANCHOR CENTERLINES	
Check Structural Opening	5
Layout Mullion and Anchor Centerlines	5
LOCATE AND INSTALL ANCHORS	6
INSTALL ANCHOR HOOKS	7
HOISTING FRAMES	8-9
STARTER SILL CONDITION	
Install Starter Sill	10
Proper Seal at Starter Sill	10-11
Install Horizontal Air Seal Gasket	12
INSTALL GROUND FLOOR FRAMES	
Install the First Frame	13-14
Install Adjacent Frames at Ground Floor	15-16
INSTALL UPPER LEVEL FRAMES	
Seal the Joint	17
Install Horizontal Air Seal Gasket	17
Seal Hoisting Holes for Windload Anchor Lug Option	18
Install First Frame at Upper Level	19
Install Adjacent Frames at Upper Level	20-21
JAMB FRAME CONDITION	22

## GENERAL INFORMATION

### PRODUCT USE

The unitized curtain wall system is intended for installation by glazing professionals with appropriate experience. Subcontractors must be qualified to provide field instruction and project management.

Oldcastle BuildingEnvelope™ does not control the application of its product configurations, sealant or glazing material and assumes no responsibility for the application. It is the responsibility of the owner, architect and installer to make these selections in strict compliance with applicable laws and building codes.

Consult silicone sealant manufacturer for review and recommendation of sealant application. Follow sealant manufacturer's recommendations and literature for proper cleaning, testing and application of silicone sealant.

The air and water performance of the unitized curtain wall is directly related to the completeness and integrity of the installation process. To ensure top performance for this system, particular attention should be given to the following procedures:

1. Surface to be sealed should be cleaned with isopropyl alcohol or solvent and dried as recommended by sealant manufacturer to remove dirt and cutting oils.
2. Vertical movement of mullion at intermediate floors requires special expansion joints and glazing materials. The system permit maximum +/-3/4" movement. For designs and applications that may require greater movement or special considerations, please contact your local Oldcastle BuildingEnvelope™ facility.

Variations on the details shown may occur, but are not the responsibility of Oldcastle BuildingEnvelope™.

### PROTECTION AND STORAGE

Handle all material carefully. Do not drop from the truck, stack with adequate separation so the material will not rub together. Store material off the ground, protecting against the elements and other construction hazards by using a well ventilated covering. Remove material from package if wet or located in a damp area. For further guidelines consult AAMA publication "Care And Handling of Architectural Aluminum From Shop To Site".

### CHECK MATERIAL

Check all material upon arrival at job site for quality and to determine any shipping damage. Using the contract documents, completely check the surrounding conditions that will receive your materials. Notify the general contractor by letter of any discrepancies before proceeding with the work. Failure to do so constitutes acceptance of work by other trades.

# SIGNATURE SERIES UNIT WALL INSTALLATION MANUAL

Check shop drawings, installation instructions, architectural drawings and shipping lists to become familiar with the project. The shop drawings take precedence and include specific details for the project. The assembly and installation instructions are of a general nature and cover the most common conditions.

Due to varying job conditions all sealant must be approved by the sealant manufacturer to ensure it will perform per conditions shown on the instructions and shop drawings. The sealant must be compatible with all surfaces in which adhesion is required, including other sealant surfaces. Use primers where directed by sealant manufacturer. Properly store sealant at the recommended temperatures and check sealant for expiry and shelf life before using.

## FIELD CONDITIONS

All material to be installed must be plumb, level and true. Aluminum to be placed in direct contact with masonry or incompatible material should be isolated with a heavy coat of zinc chromate, bituminous paint or non-metallic material unless otherwise specified. After sealant is set and a representative amount of the wall has been glazed (250 sq. ft. or more), perform a water hose test in accordance with AAMA 501.2 "Field Check of Metal Storefront, Curtain Walls and Slope Glazing Systems for Water Leakage". On large projects the hose test must be repeated during the glazing operation. Review anchors or embeds in structure as early as possible to confirm that 'as built' building structure can accommodate anticipated anchor tolerances.

## CLEANING MATERIALS

Cement, plaster terrazzo, alkaline and acid based materials used to clean masonry are very harmful to finishes. Any residue should be removed with water and mild soap immediately or permanent staining will occur. A spot test is recommended before any cleaning agent is used. Refer to the architectural finish guide in the detail catalogue.

## EXPANSION JOINTS

Expansion joints and perimeter joints shown in these instructions and in the shop drawings are shown at nominal size. Actual dimensions may vary due to perimeter conditions and/or differences in metal temperature between the time of fabrication and the time of assembly/installation. For example, a 12 foot unrestrained length of aluminum can expand or contract 3/32" over a temperature change of 50 degrees F. Any movement potential should be accounted for at the time of the assembly and installation.

# SIGNATURE SERIES UNIT WALL INSTALLATION MANUAL

## LAYOUT MULLION AND ANCHOR CENTERLINES

### GENERAL NOTE:

FRAMES ARE INTENDED TO BE INSTALLED FROM LEFT TO RIGHT WHEN VIEWED FROM EXTERIOR.

DETAILING IN THIS INSTALLATION MANUAL MAY VARY FOR SPECIFIC PROJECTS.

### 1. CHECK STRUCTURAL OPENING

Slab or beam elevation must be within adjustment of anchoring system.

Structural surfaces to receive anchoring system must be level and plumb within the adjustment limits at head, sill and jamb. See approved shop drawings for allowable adjustment.

### 2. LAYOUT MULLION AND ANCHOR CENTERLINES

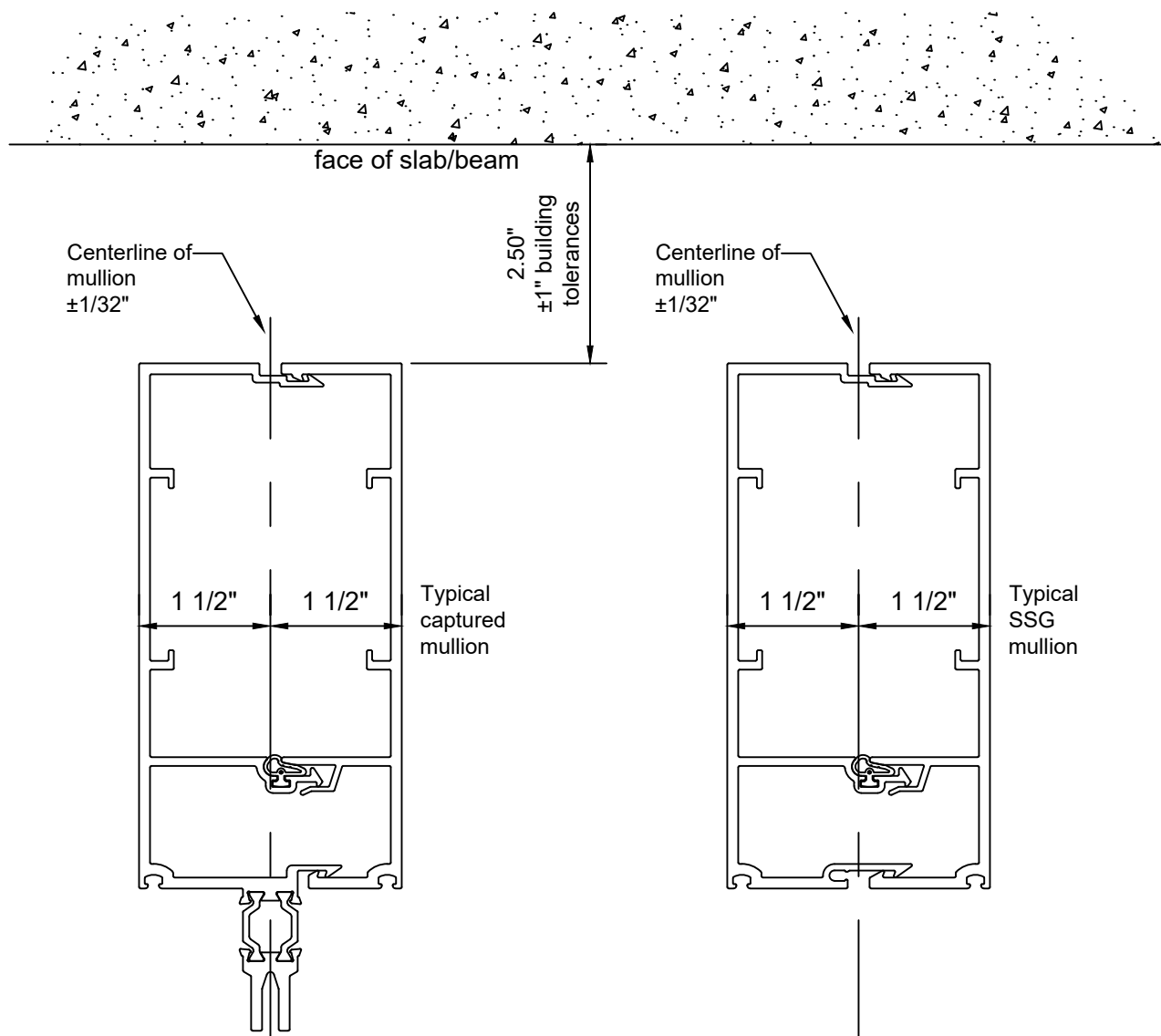

LOCATE AND INSTALL ANCHORS

1. LOCATE AND INSTALL ANCHORS

See approved shop drawings for anchor types and locations.

Locate centerline of aluminum anchor at the mark for centerline of mullion.

Adjust alum anchor bracket for in and out. Apply aluminum serrated washers. Make final in and out adjustment prior to tightening the anchor bolt in place.

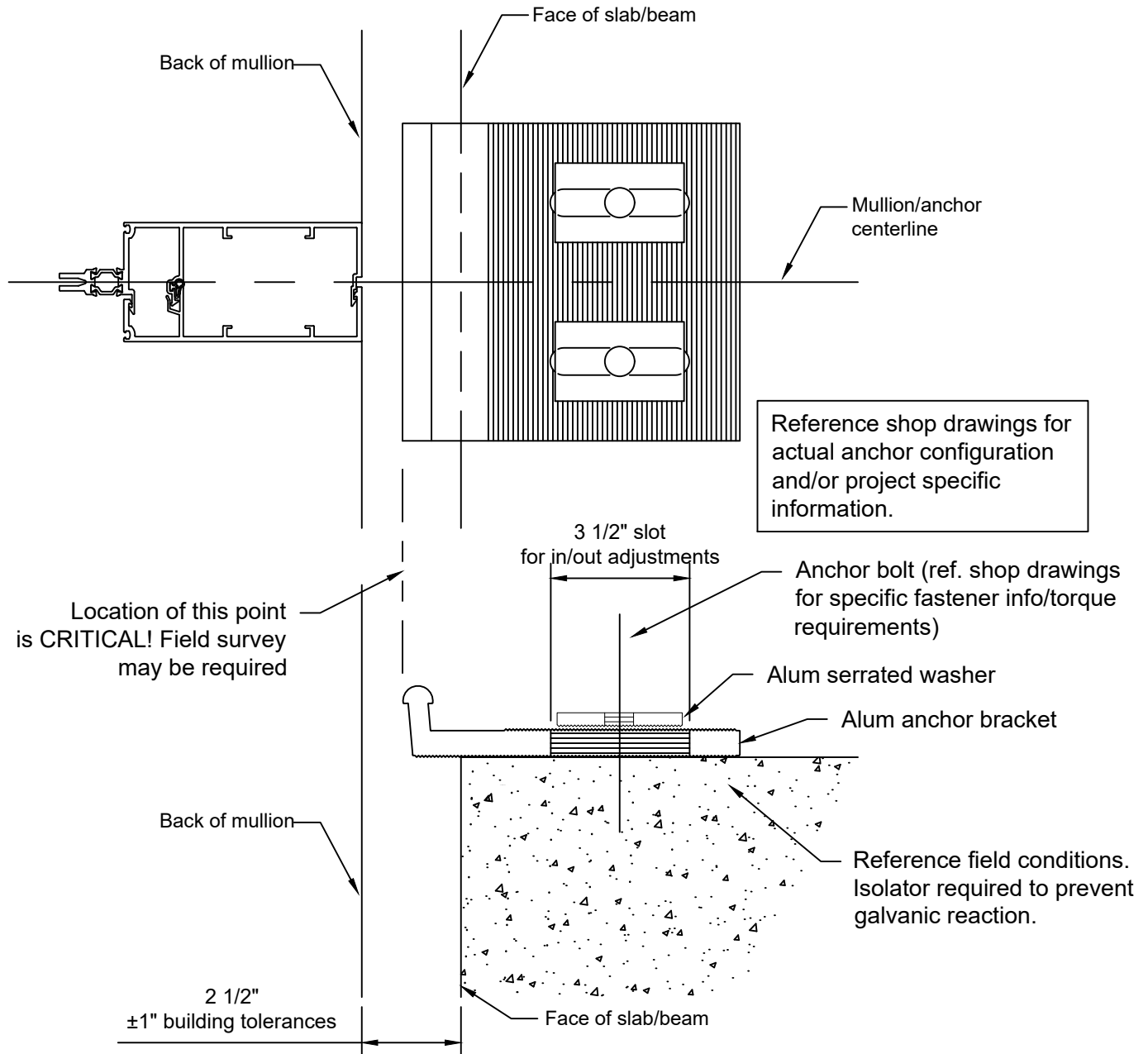

## INSTALL ANCHOR HOOKS

### 1. INSTALL ANCHOR HOOKS

Back off #10-16x $\frac{3}{4}$ " PH stopping screw at the bottom of the anchor bracket, slide in the anchor hook.

Tighten up #10-16x $\frac{3}{4}$ " the screw is to prevent anchor hook from sliding out of the anchor bracket during frame installation.

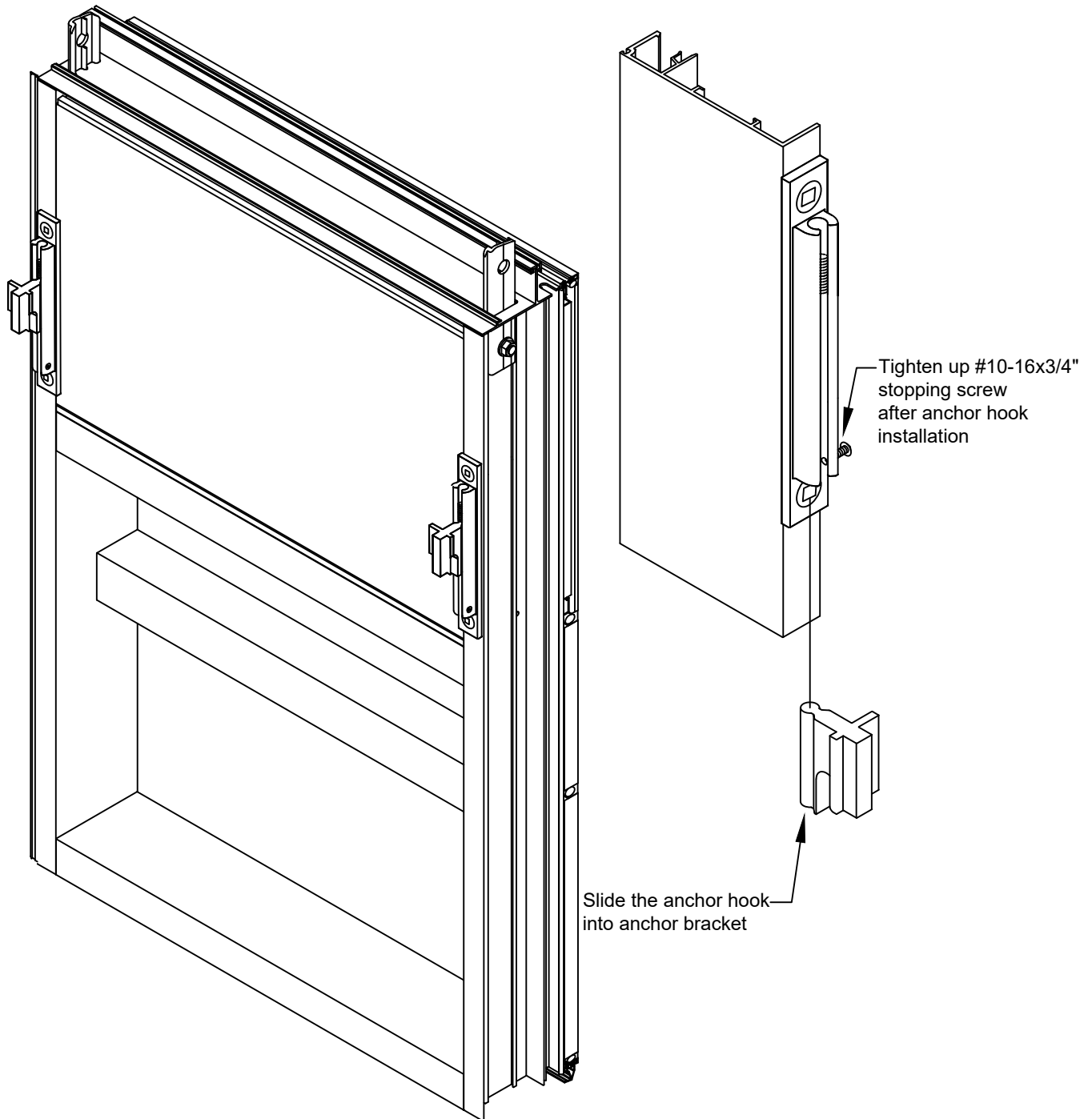



## HOISTING FRAMES

SAFETY PROCEDURES ARE THE SOLE RESPONSIBILITY OF THE INSTALLER. OLDCASTLE BUILDINGENVELOPE™ ASSUMES NO RESPONSIBILITY FOR PROJECT SAFETY PROCEDURES.

### 1. HOISTING FRAMES

Frames can be hoisted either through anchor lugs (shear angle) installed in frame head horizontals or through sleeves attached to the mullion halves.

Inspect frames prior to hoisting. For illustration purposes only, a spreader bar is shown as a hoisting device. Other lifting devices can be used. Means & methods are the sole responsibility of the installer. The spreader bar chains should be spaced the same distance as the distance between hoisting holes in head horizontal or hoisting holes on sleeves. Maximum frame weight to be less than 1500 pounds.

Handle frame to hoist smoothly and in a controlled manner, no swinging or spinning allowed during hoisting. Avoid shock loads.

Spreader bar should indicate hoisting configuration depending on frame weight. Ensure hoisting bar is rated for frame weight configuration as required.

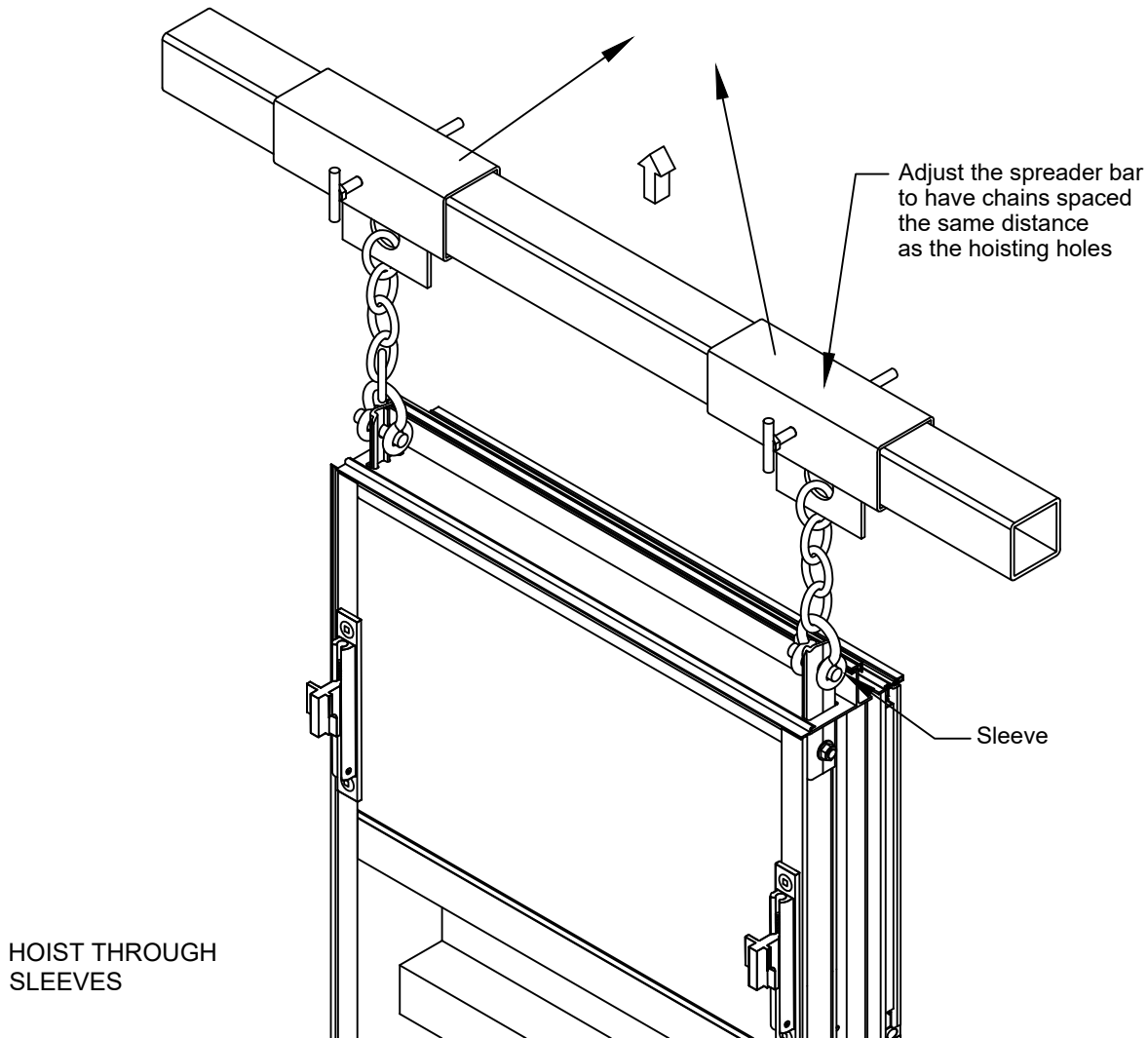

HOISTING FRAMES

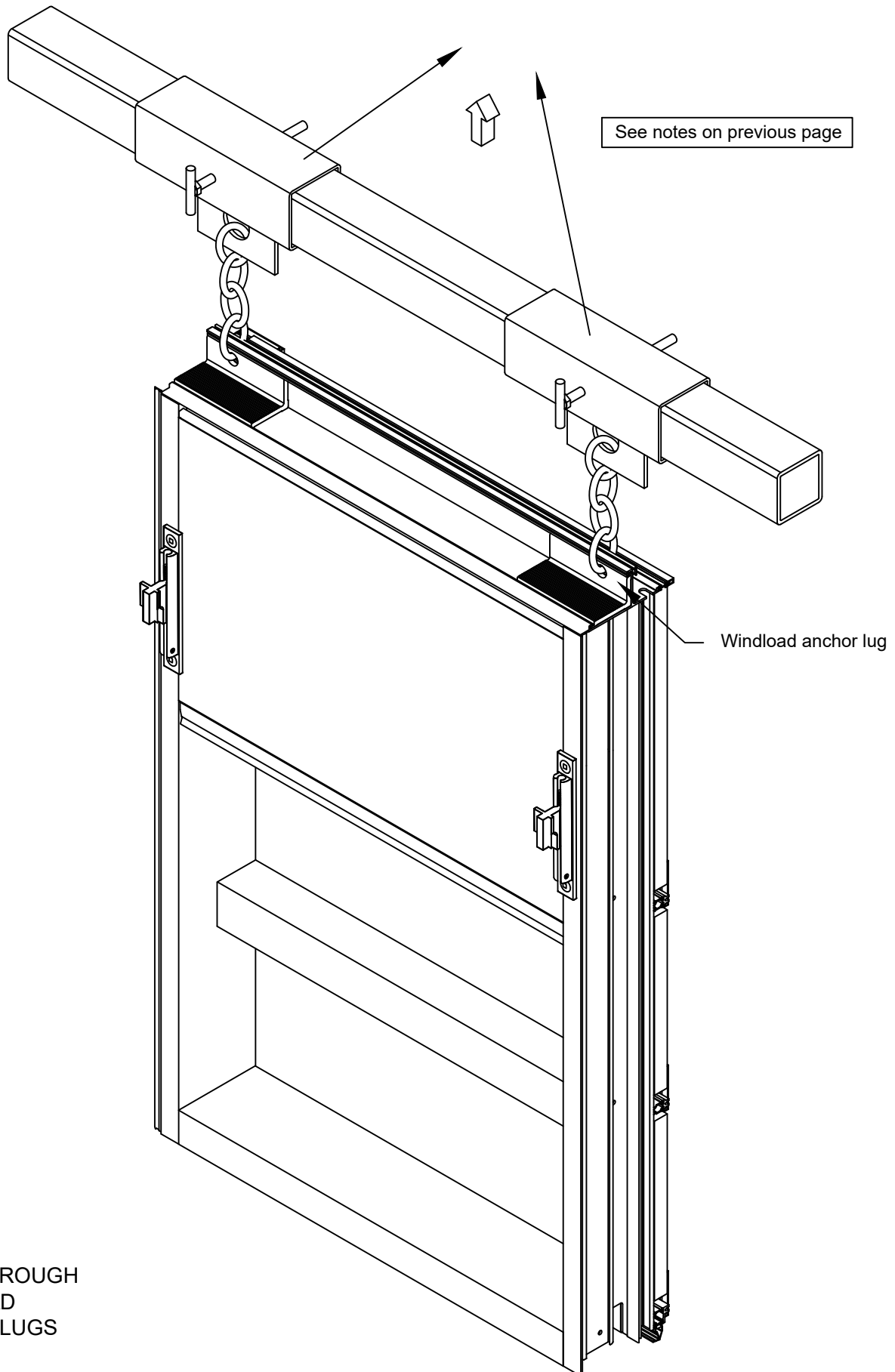

HOIST THROUGH  
WINDLOAD  
ANCHOR LUGS

## STARTER SILL CONDITION

## 1. INSTALL STARTER SILL

Locate starter sill per approved shop drawings. The starter sill must be level and straight. The starter sill should run continuously across elevation, whenever the splicing is necessary, a min. 3/16" gap should be left for proper seal in-between starter sills.

Install windload anchor lug at each mullion location, crimp the windload anchor lug in place on starter sill. Install starter sill fasteners. Ensure fastener heads will not interfere with frame sill horizontals. Seal over all fastener heads and tool sealant.

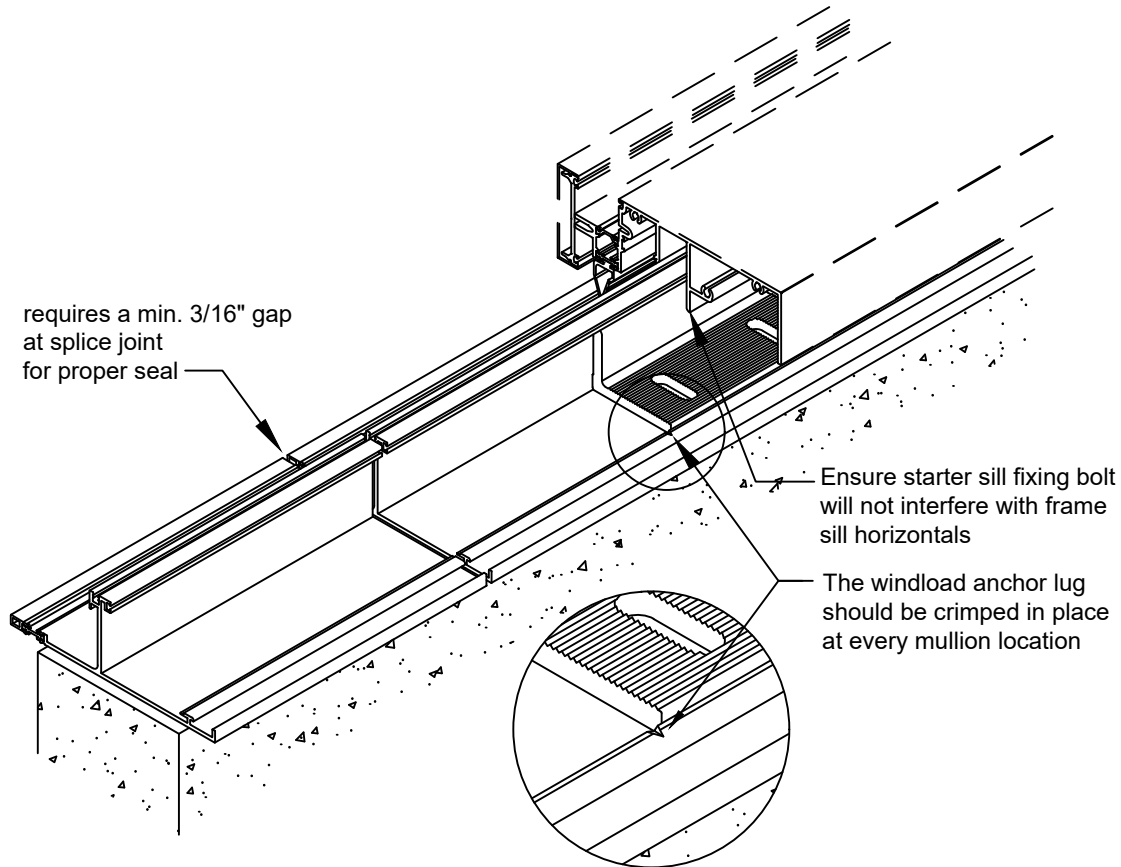

## 2. PROPER SEAL AT STARTER SILL

Clean and prepare substrates for sealing per sealant manufacturer's recommendations. Apply backer rod and perimeter seals under starter sill. Tool sealant. Apply sealant at splice joints. All splice joints should be sealed from the drainage hole on the starter sill to the top of the upturned leg. Connect sealant at underside of starter sill with sealant at splice joint. See illustration on p.11.

Apply sealant at outer surface for approximately 1" on each side of the joint as shown; set 1-1/2" wide by 3" long silicone sheet on top of the silicone sealant.

STARTER SILL CONDITION

Seal from the drain hole  
to the top of the upturned leg

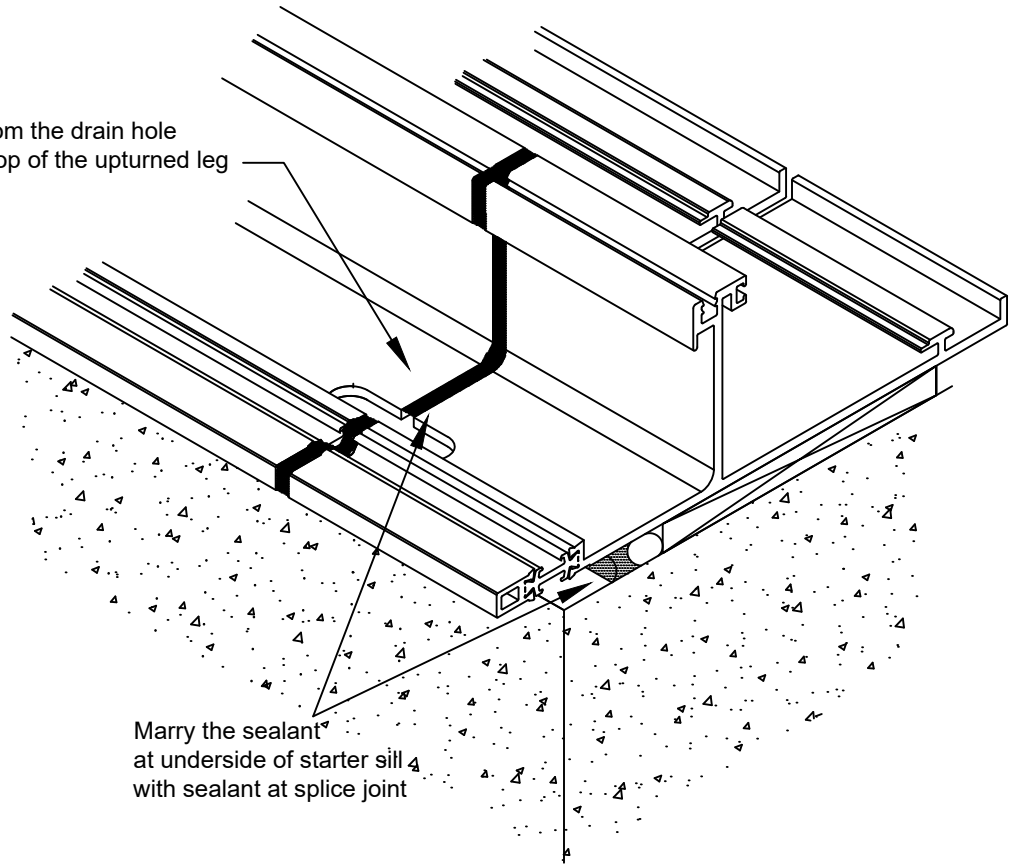

Marry the sealant  
at underside of starter sill  
with sealant at splice joint

set the 1-1/2" wide silicone  
sheet in silicone sealant  
at starter sill joint location

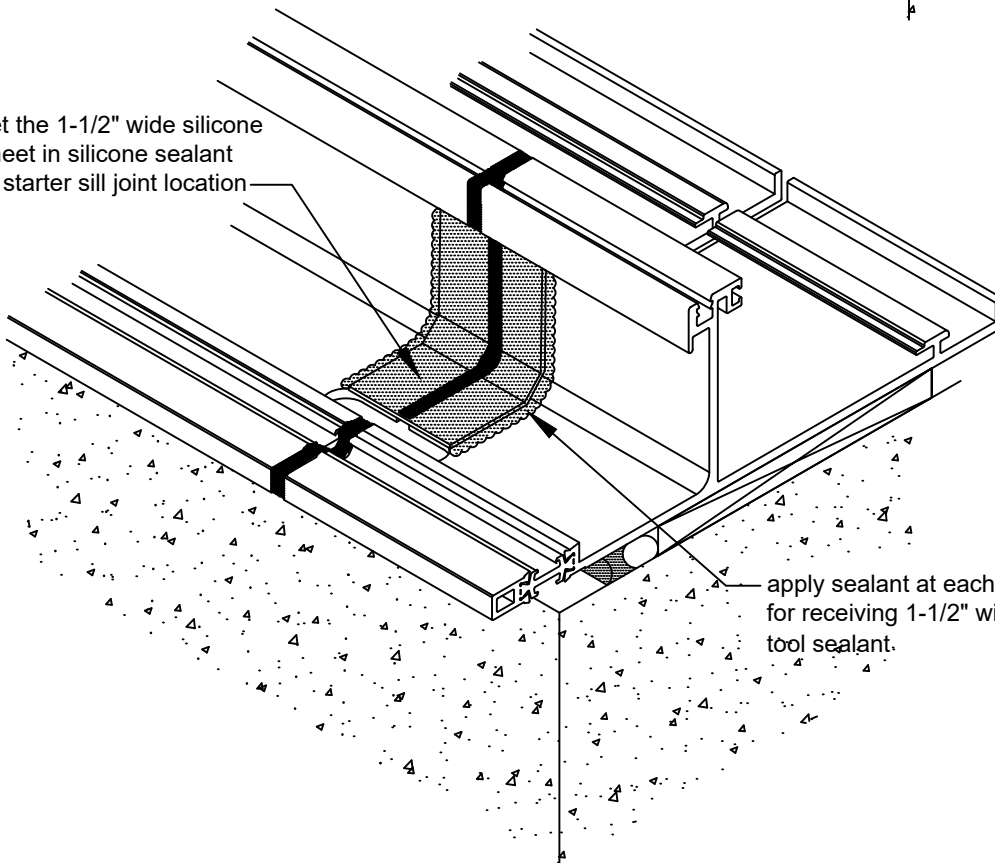

apply sealant at each end of starter sills  
for receiving 1-1/2" wide silicone sheet  
tool sealant.

## STARTER SILL CONDITION

### 3. INSTALL HORIZONTAL AIR SEAL GASKET

Clean areas to receive sealant as per sealant manufacturer's recommendations. Install horizontal air seal gasket GP-185 into starter sills continuously across elevation. Where splicing is necessary, locate the joint at mid-point of the module, apply bead of sealant to set the ends of gasket in place. Tool squeeze out sealant.

Note silicone must adhere to EPDM gasket e.g. Dow 756 silicone sealant. Ensure fingers of horizontal air seal gaskets are not filled with silicone as this will hamper frame installation.

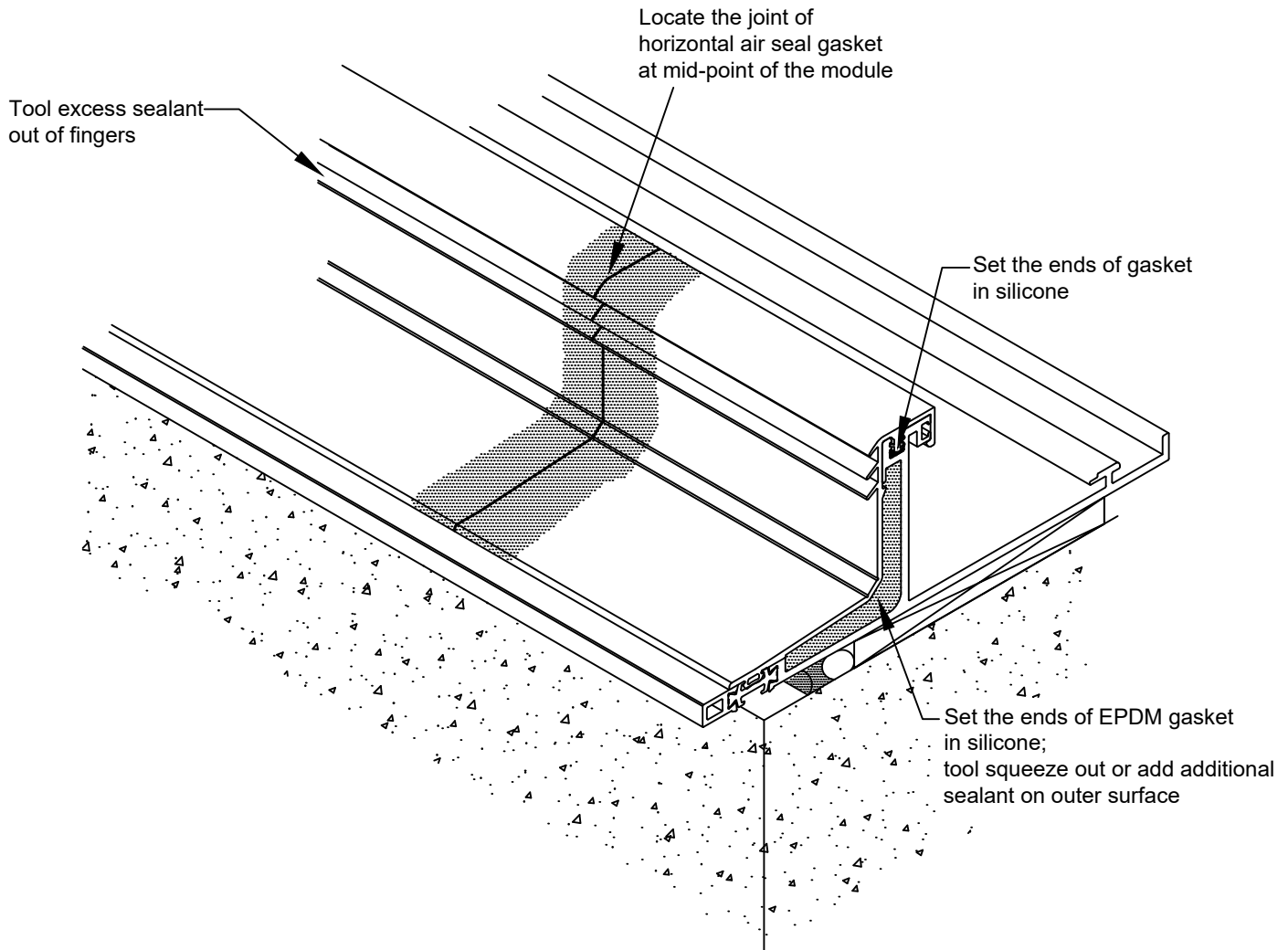

## INSTALL GROUND FLOOR FRAMES

### 1. INSTALL THE FIRST FRAME

Frames are installed from left to right and from bottom to top.

Before proceeding to installing first frame, check all starter sill joints to make sure they are properly sealed and horizontal air seal gaskets have been applied.

Apply 3" to 6" long silicone sealant towards exterior portion of the horizontal air seal gasket on top of starter sill at each end, flatten the sealant at top. Do not allow sealant to skin before installing frame.

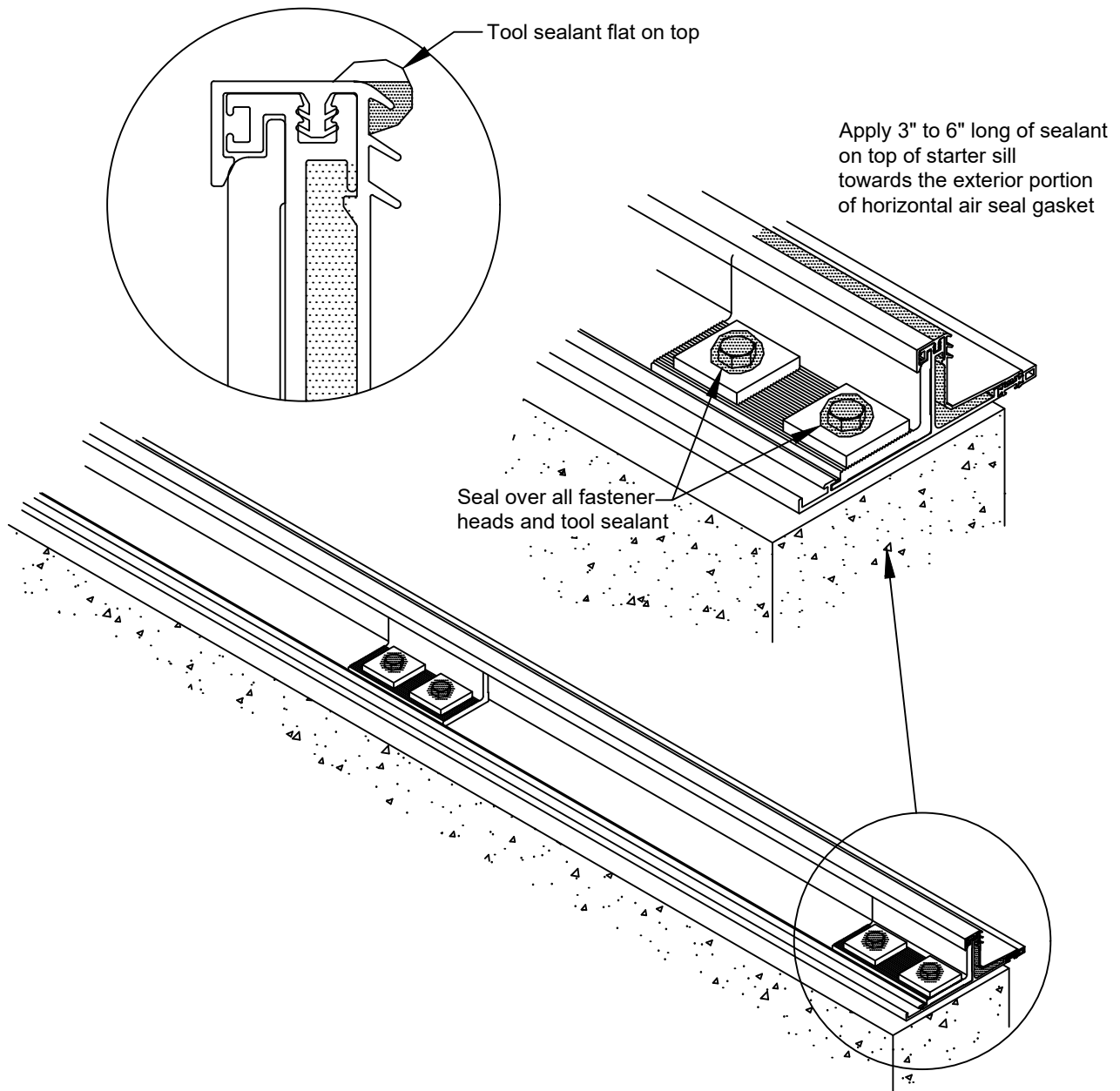

# SIGNATURE SERIES UNIT WALL INSTALLATION MANUAL

## INSTALL GROUND FLOOR FRAMES

Install the first frame by lifting the frame over starter sill and lower the frame down and rest the anchor hook on pre-set alum anchor at slab/beam.

Use the adjustment bolt on anchor bracket to adjust the elevation of the frame. Adjust the elevation of the frame to make sure the frame is level, plumb and at the correct height. After adjustment, freeze the anchor hook for lateral movement by installing #10-16x1/2" B point screw. Use metal shims if necessary to maintain the nominal distance between bottom of the mullion and top of the starter sill. Remove shims after adjustment for slip anchor condition at ground floor.

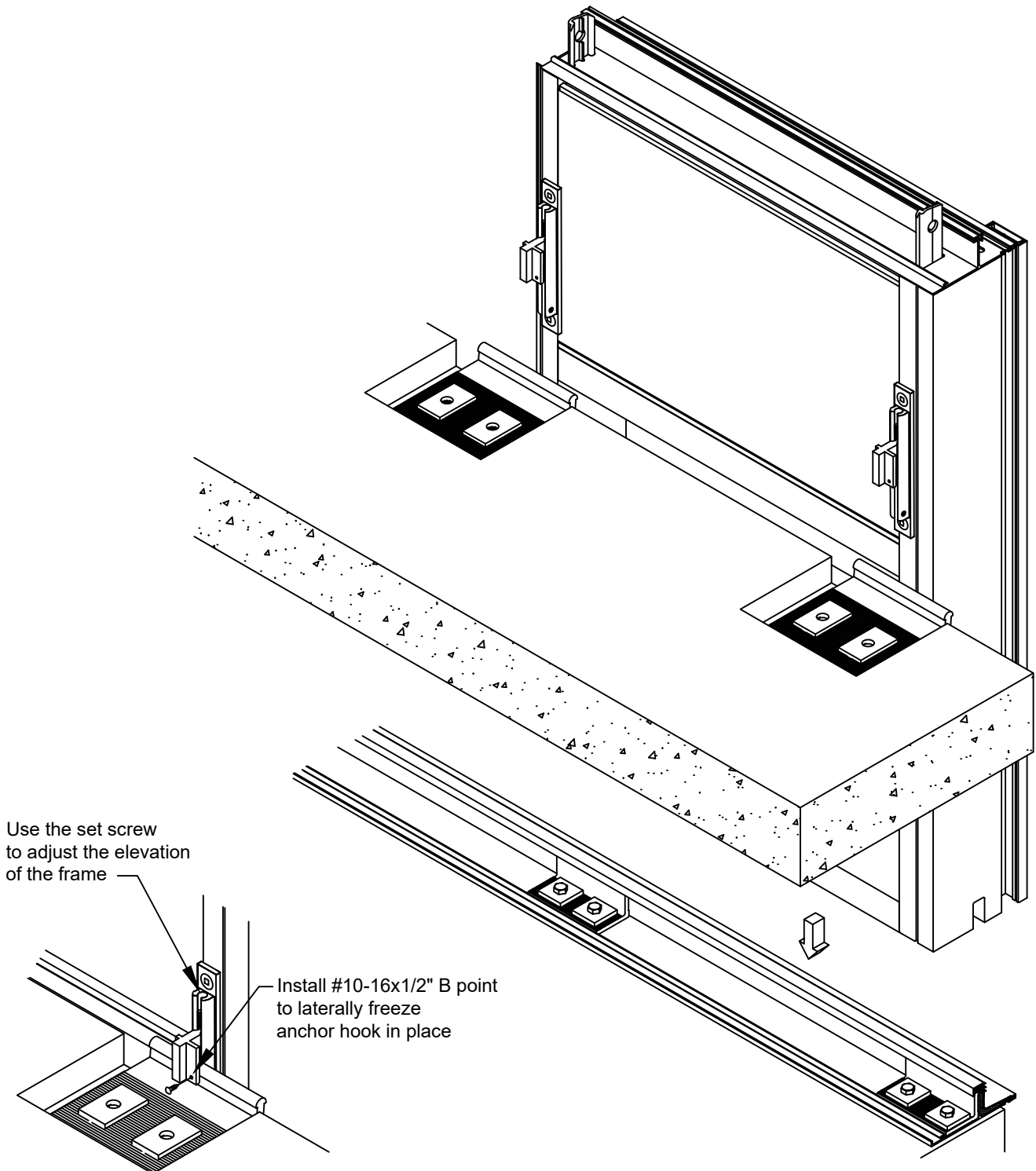

## INSTALL GROUND FLOOR FRAMES

## 2. INSTALL ADJACENT FRAMES AT GROUND FLOOR

Just prior to installing the next frame, apply sealant at the bottom of the first frame up vertical air seal gasket GP-50001 for approximately 4" long above horizontal air seal gasket. Connect the vertical seal with the horizontal seal which was previously applied on top of the starter sill. Do not allow sealant to skin before installing next frame.

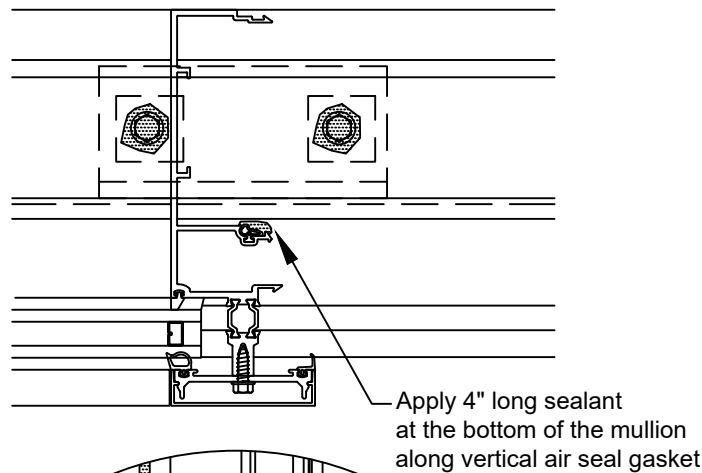

Connect vertical seal  
with horizontal seal

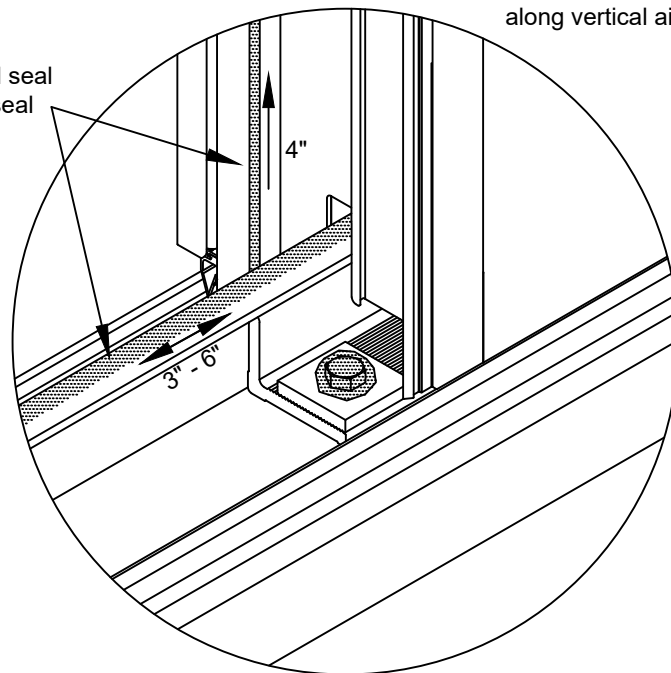

Install the next frame by lifting the frame up to clear the starter sill. Move the next frame to the left to engage the outer mullion hooks; then rotate the next frame towards building to snap inner hooks; once snapped, slide the next frame down to engage horizontal air seal at stack joint.

Again use the adjustment bolt to level the frame. Check and ensure vertical air seal gasket GP-50001 has not slid down in the gasket raceway in mullion.

Repeat in the same method for installing the rest of the frames at ground floor.



INSTALL GROUND FLOOR FRAMES

1. Lift the next frame up to clear the starter sill
2. Move to the left to engage the outer hook
3. Rotate the frame towards the building
4. Engage the inner hook
5. Slide the next frame down to engage horizontal air seal

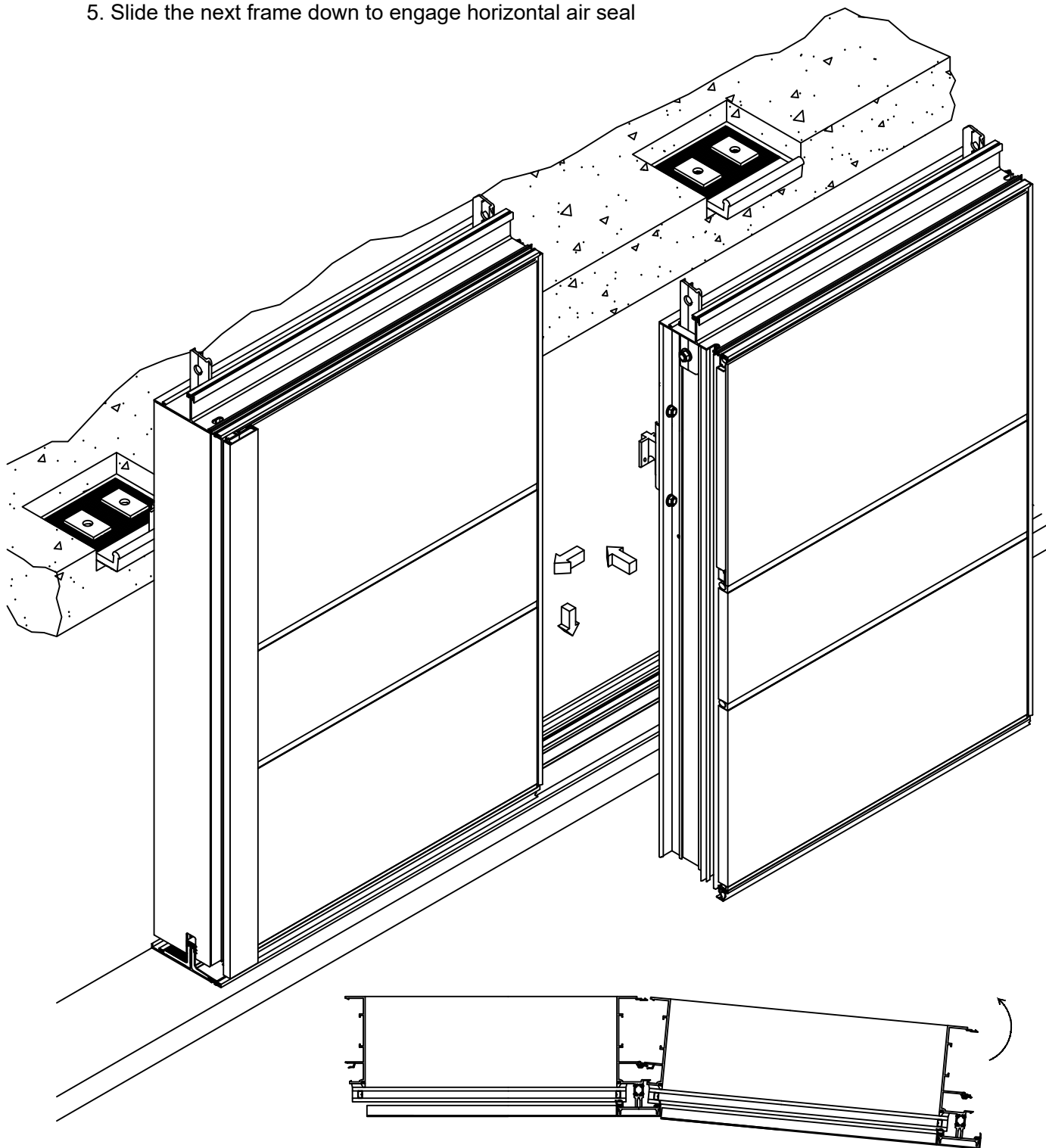

## INSTALL UPPER LEVEL FRAMES

## 1. SEAL THE JOINTS

Clean and prepare the surfaces of the head horizontal at mullion joints per sealant manufacturer's commendations. Apply sealant completely along the entire joint between head horizontals; also apply sealant at front face for approximately 1" on each side of the joint as shown; set 1-1/2" wide by 2-5/8" long silicone sheet on top of the silicone sealant.

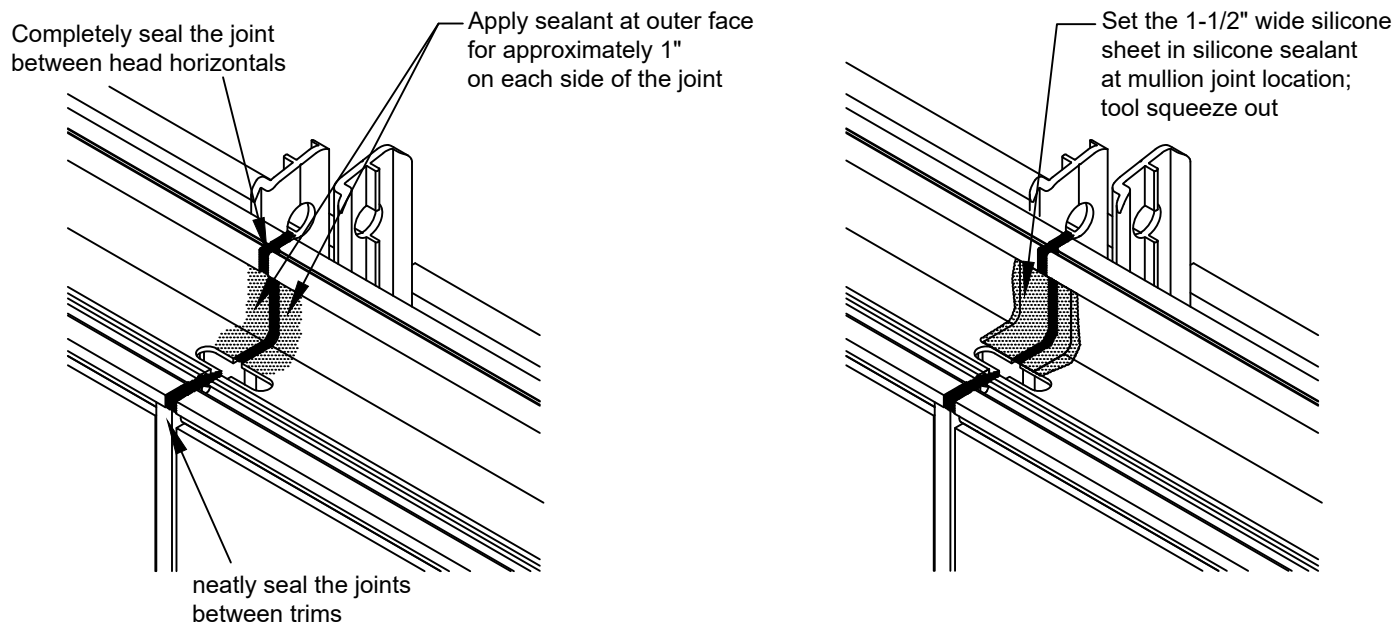

## 2. INSTALL HORIZONTAL AIR SEAL GASKET

Install horizontal air seal gasket GP-601 into head horizontals continuously across elevation. Apply sealant for approximately 3" long on each side of the splice joint, push gasket into raceway, tool squeeze out sealant. Where splicing is necessary, locate the joint at mid-point of the module and apply bead of sealant to set the ends of gasket in place. Push in the next piece of gasket, tool squeeze out sealant and remove excess sealant from outer face.

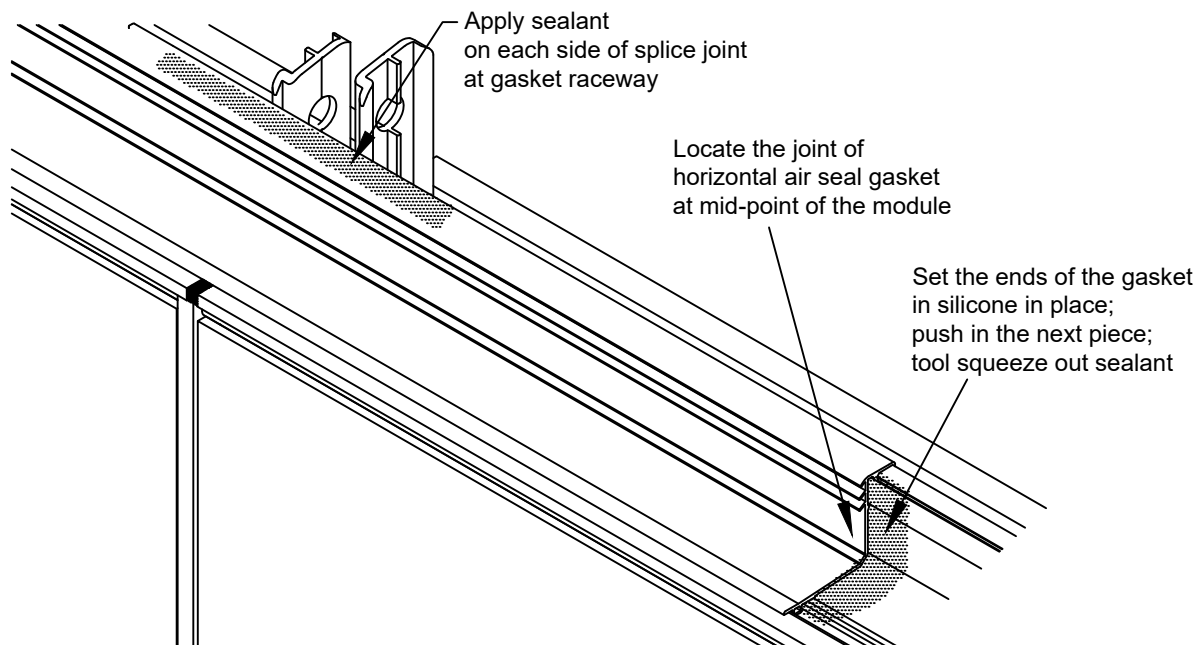

## INSTALL UPPER LEVEL FRAMES

## 3. SEAL THE HOISTING HOLES FOR WINDLOAD ANCHOR LUG OPTION

For frames with windload anchor lug (shear angle) option, clean and prepare the surfaces of the head horizontal at mullion joints; apply sealant completely along the entire joint between head horizontals; also apply sealant at and around hoisting hole, set 2" by 2" alum plate at hoisting hole location.

Similar to frames with sleeve option, apply sealant to outer face for approximately 1" on each side of the joint as shown; set 1-1/2" wide by 2-5/8" long silicone sheet on top of the silicone sealant.

Then install horizontal air seal gasket GP-601 into head horizontals continuously across elevation. Where splicing is necessary, to locate the joint at mid-point of the module and apply bead of sealant and set the ends of gasket in place. Tool squeeze out sealant.

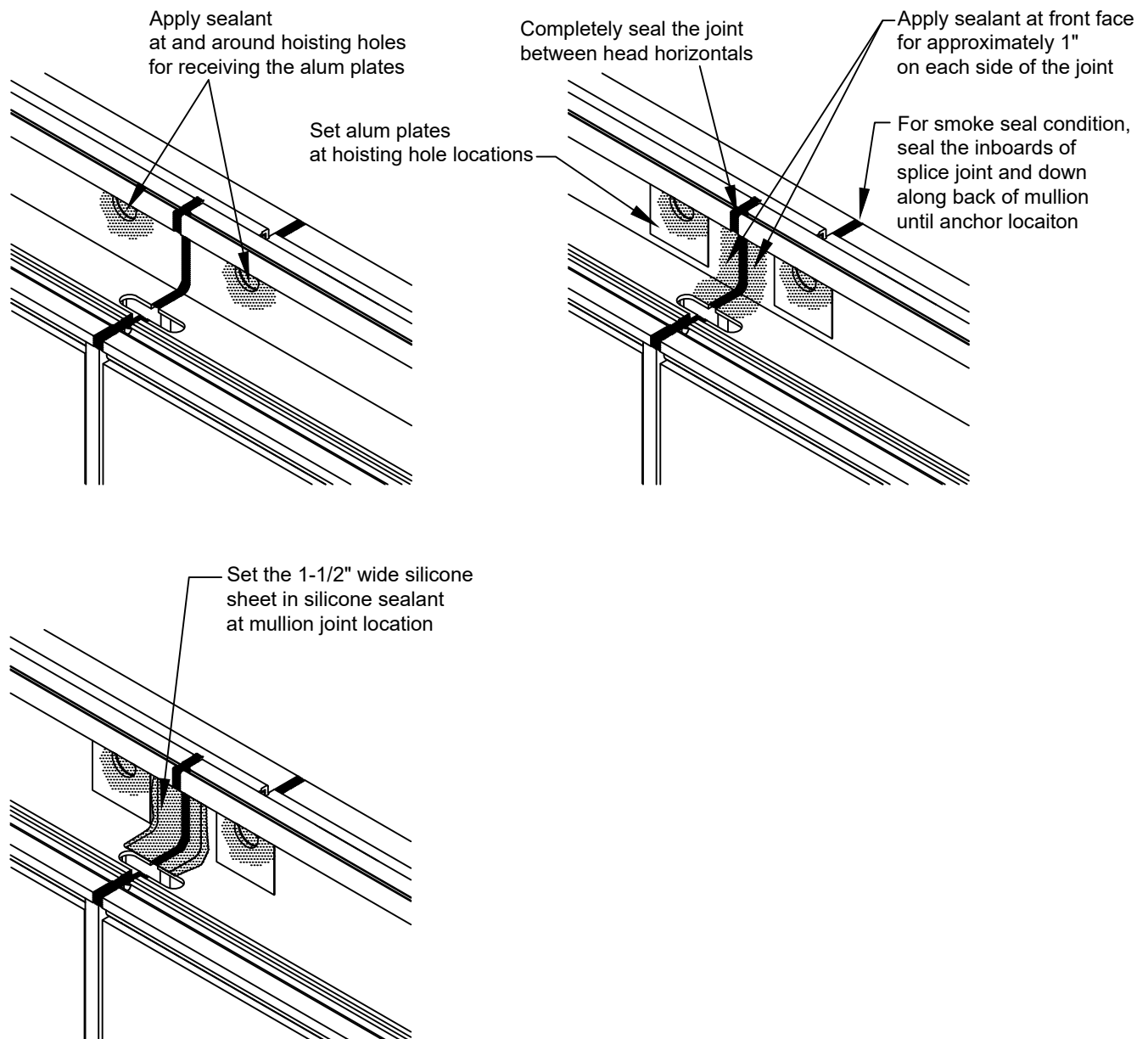

## INSTALL UPPER LEVEL FRAMES

## 4. INSTALL FIRST FRAME AT UPPER LEVEL

Before proceeding to upper level, check all horizontal joints at lower level to make sure they are properly sealed and horizontal air seal gaskets have been applied.

Apply a 3" to 6" long bead of silicone sealant towards exterior portion of the horizontal air seal gasket on top of head horizontal at each end at the frame below, flatten the sealant at top; Install the first frame at upper level by lifting the frame over head horizontal and lower the frame down.

Use the adjustment bolt on anchor bracket to adjust the elevation of the frame. Use shims if necessary to maintain the nominal distance between bottom of the mullion and top of the head horizontal. Remove shims after adjustment.

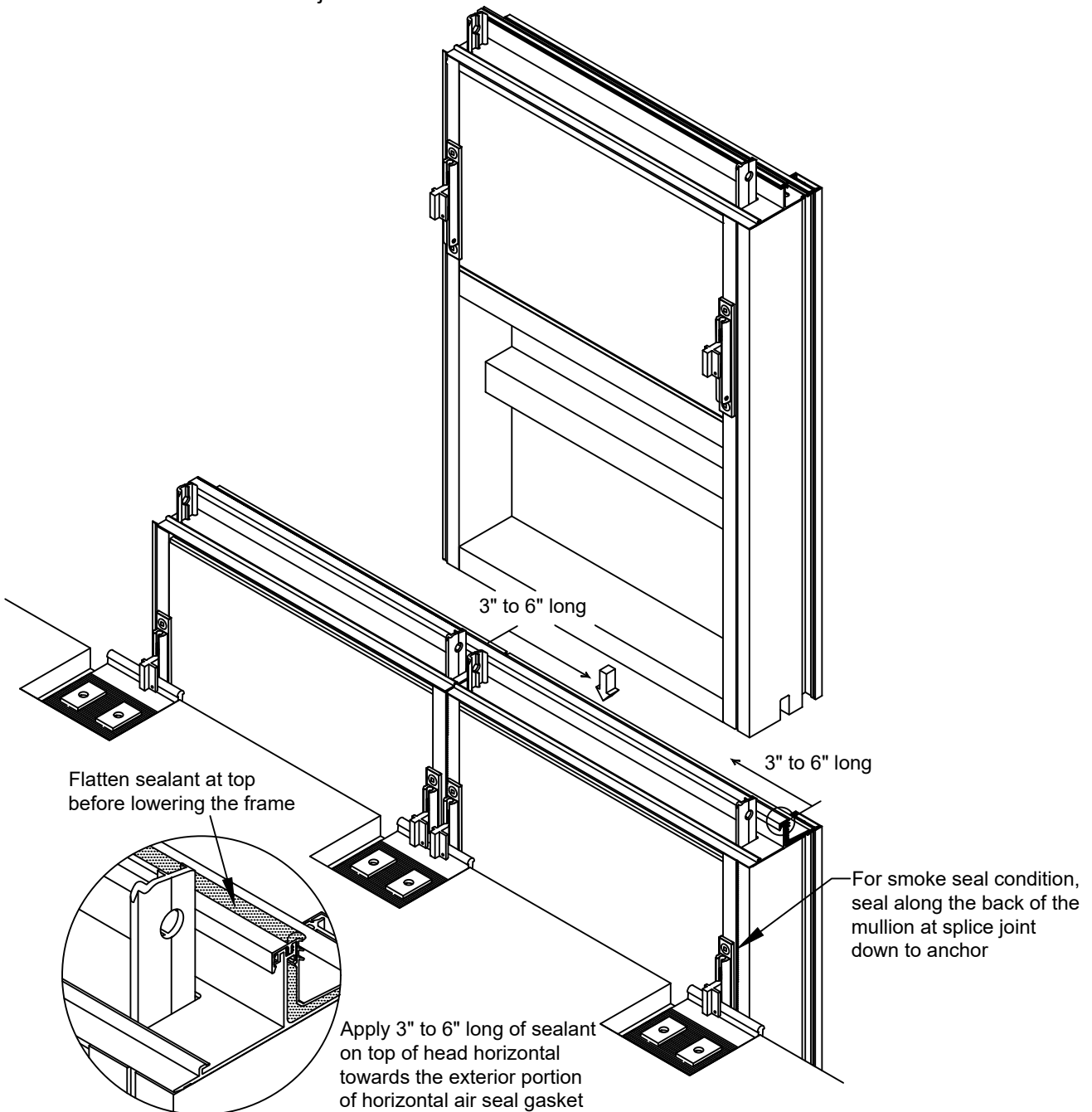

## INSTALL UPPER LEVEL FRAMES

## 5. INSTALL ADJACENT FRAMES AT UPPER LEVEL

Just prior to installing the next frame, apply sealant at the bottom of the first frame up vertical air seal gasket GP-50001 for approximately 4" long above horizontal air seal gasket. Connect the vertical seal with the horizontal seal which was previously applied on top of the head horizontal.

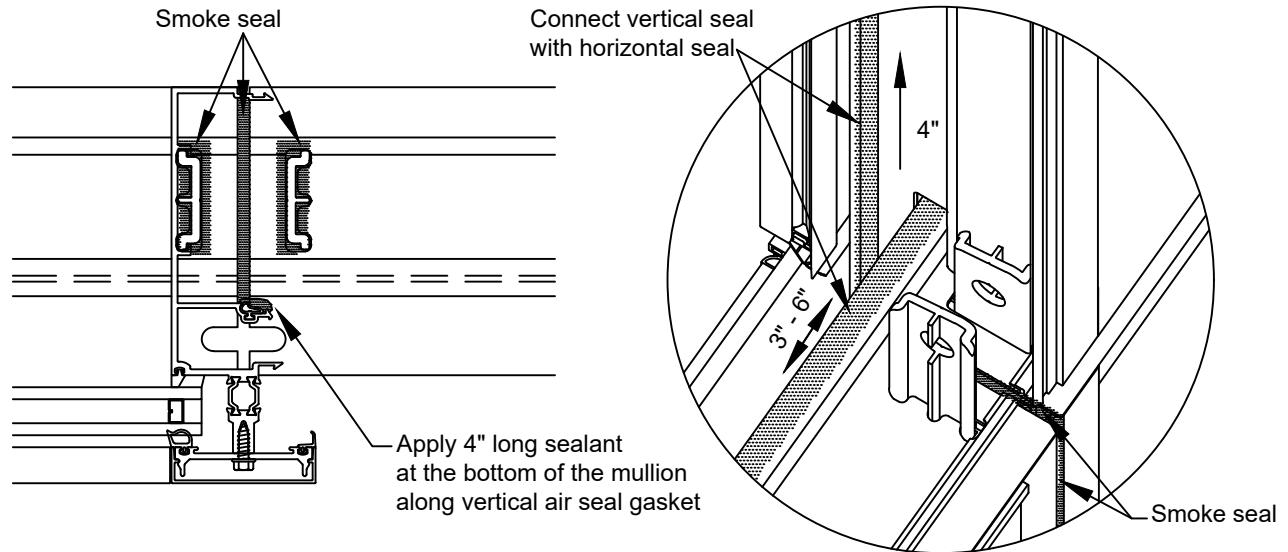

Install the next frame by lifting the frame 4" to 6" above previous frame to clear the sleeves and head horizontals. Move the next frame to the left to engage the outer mullion hooks; then rotate the next frame towards building to snap inner hooks; once snapped, slide the next frame down to engage horizontal air seal at stack joint.

Again use adjustment bolt on anchor bracket to adjust the elevation of the frame, then freeze the lateral movement by installing #10-16x $\frac{1}{2}$ " B point screw on anchor hook.

Repeat in the same method for installing the rest of the frames.

INSTALL UPPER FLOOR FRAMES

1. Lift the next frame up to clear the sleeve
2. Move to the left to engage the outer hook
3. Rotate the frame towards the building
4. Engage the inner hook
5. Slide the next frame down to engage horizontal air seal

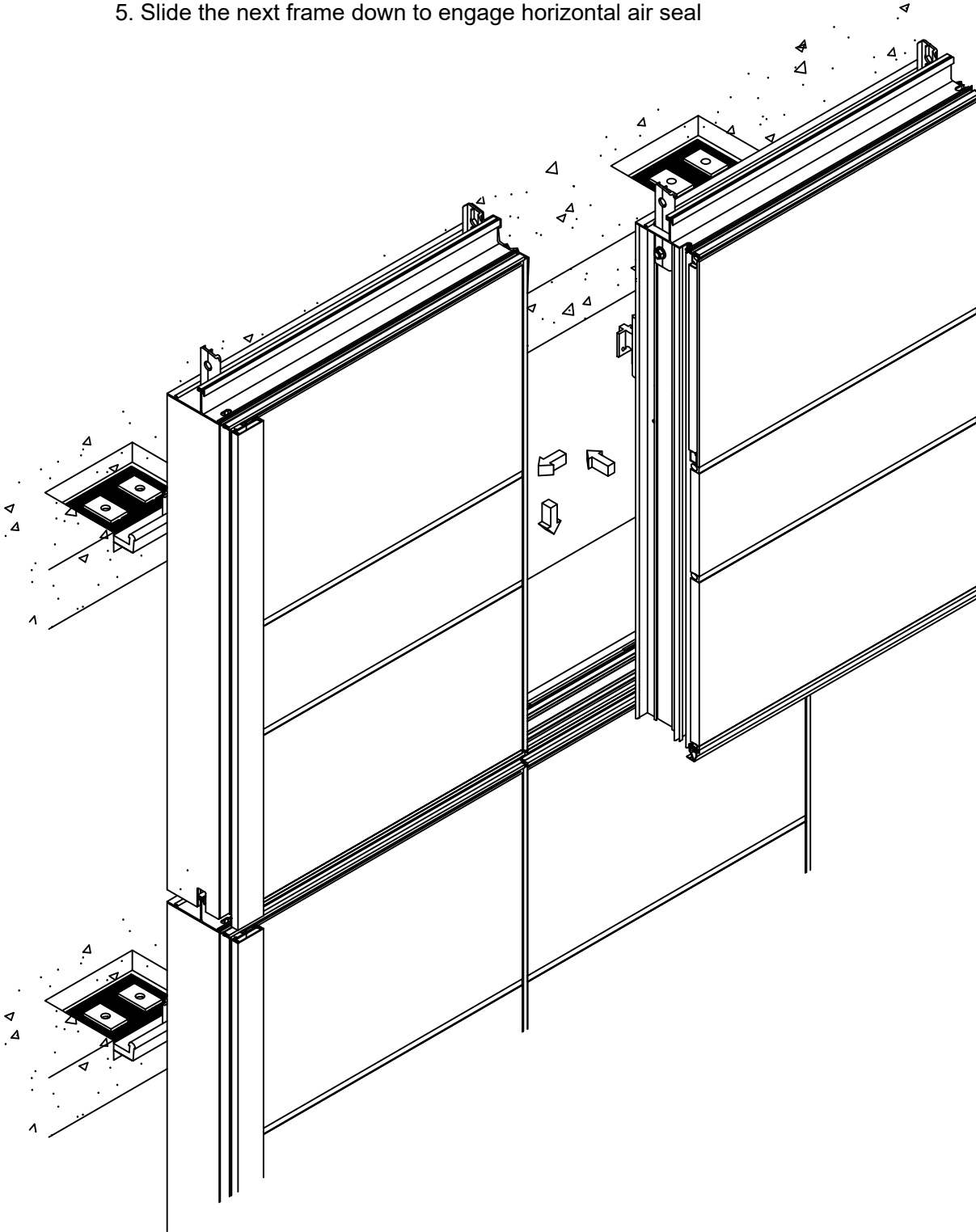

JAMB FRAME CONDITION

1. SEAL AT THE NOTCH ON JAMB MULLION

For jamb frames at expansion joints or starter sills, apply sealant at the notch on mullion above and below the expansion joint. Set 4" wide by 6" long silicone sheet in place.

